

## Contents

### American National Standards

<b>Call for Comment on Standards Proposals</b> .....	<b>2</b>
<b>Call for Members (ANS Consensus Bodies)</b> .....	<b>25</b>
<b>Final Actions</b> .....	<b>28</b>
<b>Project Initiation Notification System (PINS)</b> .....	<b>29</b>
<b>ANS Maintained Under Continuous Maintenance</b> .....	<b>33</b>
<b>ANSI-Accredited Standards Developers Contact Information</b> .....	<b>34</b>

### International Standards

<b>ISO and IEC Draft Standards</b> .....	<b>35</b>
<b>ISO Newly Published Standards</b> .....	<b>37</b>
<b>Proposed Foreign Government Regulations</b> .....	<b>39</b>
<b>Information Concerning</b> .....	<b>40</b>

## American National Standards

### Call for comment on proposals listed

This section solicits public comments on proposed draft new American National Standards, including the national adoption of ISO and IEC standards as American National Standards, and on proposals to revise, reaffirm or withdraw approval of existing American National Standards. A draft standard is listed in this section under the ANSI-accredited standards developer (ASD) that sponsors it and from whom a copy may be obtained. Comments in connection with a draft American National Standard must be submitted in writing to the ASD no later than the last day of the comment period specified herein. Such comments shall be specific to the section(s) of the standard under review and include sufficient detail so as to enable the reader to understand the commenter's position, concerns and suggested alternative language, if appropriate. Please note that the ANSI Executive Standards Council (ExSC) has determined that an ASD has the right to require that interested parties submit public review comments electronically, in accordance with the developer's procedures.

#### Ordering Instructions for "Call-for-Comment" Listings

1. **Order from the organization indicated for the specific proposal.**
2. **Use the full identification in your order, including the BSR prefix; for example, Electric Fuses BSR/SAE J554.**
3. **Include remittance with all orders.**
4. **BSR proposals will not be available after the deadline of call for comment.**

Comments should be addressed to the organization indicated, with a copy to the Board of Standards Review, American National Standards Institute, 25 West 43rd Street, New York, NY 10036. Fax: 212-840-2298; e-mail: [psa@ansi.org](mailto:psa@ansi.org)

\* Standard for consumer products

# Call for Comment of Limited Substantive Changes to an Approved ANS

## 30-Day Call for Comment Deadline: November 4, 2018

### PMMI – The Association for Packaging and Processing Technologies

#### ANSI PMMI B155.1-2016

This standard specifies basic terminology, principles and a methodology for achieving safety in the design and the use of machinery. It specifies principles of the iterative process of risk assessment and risk reduction to help designers, integrators and users of machinery in achieving this objective. Procedures are described for identifying hazards and estimating and evaluating risks during relevant phases of the machine life cycle, and for the elimination of hazards or the provision of sufficient risk reduction.

The requirements of this standard apply to new, modified or rebuilt industrial and commercial:

- processing machinery used to produce food, beverage and pharmaceutical products;
- packaging machinery that performs packaging functions for primary, secondary, and tertiary (transport / distribution) packaging;
- coordination of the packaging functions that take place on the production line; and
- packaging-related converting machinery.

The standard does not include packaging or processing machinery used by retail consumers.

#### Public Review

PMMI is submitting two changes for public review:

ANSI PMMI B155.1-2006 introduced the use of the iterative process of risk assessment for achieving acceptable risk for packaging and processing related converting machinery.

This standard formed the basis for the ANSI B11.0 *Safety of Machinery – General Requirements and Risk Assessment* which was published in 2010 and subsequently revised in 2015. Certain language from the 2015 revision was inadvertently carried over to the 2016 revision of ANSI PMMI B155.1.

ANSI B11.0-2015 and ANSI PMMI B155.1-2016 both require machinery suppliers use the iterative process of risk assessment to achieve acceptable risk. However, the scope of the machinery covered by the standards is different.

**In clause 4.4.3** the PMMI B155.1 committee felt the reference to “any applicable B11 standard” was unnecessary and potentially confusing because none of the B11 base standards apply to packaging machinery. (e.g. ANSI B11.0 - 2015 lists 24 B11 standards for specific machine tools.) Therefore this text is being deleted.

**In clause 9.2.1** a sentence was added regarding “refresher training”. PMMI B155.1-2016 lists NFPA 86 - 2015 *Standard for Ovens and Furnaces* as a “normative reference”. NFPA 86 has specific requirements regarding “refresher training”. The PMMI B155.1-2016 committee the supported addition of “refresher training”.

Single copy price: \$140.00

Order paper copy from: <https://webstore.ansi.org/>

Send comments (with copy to [psa@ansi.org](mailto:psa@ansi.org)) to: [fhayes@pmmi.org](mailto:fhayes@pmmi.org)

Obtain an electronic copy from: [fhayes@pmmi.org](mailto:fhayes@pmmi.org)

**Public review is limited to the revisions shown in the linked pages.**

[Click here to view these changes in full](#)

## Comment Deadline: November 4, 2018

### ASHRAE (American Society of Heating, Refrigerating and Air-Conditioning Engineers, Inc.)

#### **Addenda**

BSR/ASHRAE Addendum 34q-201x, Designation and Safety Classification of Refrigerants (addenda to ANSI/ASHRAE Standard 34-2016)

This addendum moves the cis (E) and trans (Z) isomer description from section 4.1.10 (isomers of propene series) to a new standalone section (4.1.13).

[Click here to view these changes in full](#)

Send comments (with copy to [psa@ansi.org](mailto:psa@ansi.org)) to: <https://osr.ashrae.org/default.aspx>

BSR/ASHRAE Addendum 34r-201x, Designation and Safety Classification of Refrigerants (addenda to ANSI/ASHRAE Standard 34-2016)

This addendum corrects language to allow for proper naming of molecules containing iodine.

[Click here to view these changes in full](#)

Send comments (with copy to [psa@ansi.org](mailto:psa@ansi.org)) to: <https://osr.ashrae.org/default.aspx>

BSR/ASHRAE Addendum 34s-201x, Designation and Safety Classification of Refrigerants (addenda to ANSI/ASHRAE Standard 34-2016)

This addendum adds the single component refrigerant R-1336mzz(E) in Table 4-1.

[Click here to view these changes in full](#)

Send comments (with copy to [psa@ansi.org](mailto:psa@ansi.org)) to: <https://osr.ashrae.org/default.aspx>

BSR/ASHRAE Addendum 34t-201x, Designation and Safety Classification of Refrigerants (addenda to ANSI/ASHRAE Standard 34-2016)

This addendum adds the single component refrigerant R-1311 in Table 4-1.

[Click here to view these changes in full](#)

Send comments (with copy to [psa@ansi.org](mailto:psa@ansi.org)) to: <https://osr.ashrae.org/default.aspx>

BSR/ASHRAE Addendum 34u-201x, Designation and Safety Classification of Refrigerants (addenda to ANSI/ASHRAE Standard 34-2016)

This addendum adds the zeotropic refrigerant blend R-466A in Table 4-2.

[Click here to view these changes in full](#)

Send comments (with copy to [psa@ansi.org](mailto:psa@ansi.org)) to: <https://osr.ashrae.org/default.aspx>

BSR/ASHRAE Addendum 34v-201x, Designation and Safety Classification of Refrigerants (addenda to ANSI/ASHRAE Standard 34-2016)

This addendum revises paragraph B2.4.1 (Leaks Under Storage/Shipping Conditions) to address fluids whose critical temperature is lower than 130°F (54.4°C).

[Click here to view these changes in full](#)

Send comments (with copy to [psa@ansi.org](mailto:psa@ansi.org)) to: <https://osr.ashrae.org/default.aspx>

### ASME (American Society of Mechanical Engineers)

#### **New Standard**

BSR/ASME Y14.47-201x, 3D Model Organization Schema (new standard)

This standard establishes a schema for organizing three-dimensional (3D) model and other associated information within the context of a digital product definition data set for the purpose of conveying a product definition that enables a Model-Based Enterprise (MBE).

[Click here to view these changes in full](#)

Send comments (with copy to [psa@ansi.org](mailto:psa@ansi.org)) to: Fredric Constantino, (212) 591-8684, [constantinof@asme.org](mailto:constantinof@asme.org)

## **IIAR (International Institute of Ammonia Refrigeration)**

### **Revision**

BSR/IIAR 7-201x, Developing Operating Procedures for Closed-Circuit Ammonia Refrigeration Systems (revision of ANSI/IIAR 7-2013)

The purpose of this standard is to define the minimum requirements for developing procedures for closed-circuit ammonia refrigeration systems.

[Click here to view these changes in full](#)

Send comments (with copy to [psa@ansi.org](mailto:psa@ansi.org)) to: [tony\\_lundell@iiar.org](mailto:tony_lundell@iiar.org)

BSR/IIAR 2-2014, Addendum A-201x, Standard for the Safe Design of Closed-Circuit Ammonia Refrigeration Systems (revision of ANSI/IIAR 2-2014)

The standard provides the minimum requirements for the design of safe anhydrous ammonia refrigeration systems. This addendum will correct mistakes and provide clarity to IIAR 2-2014 and will also add absorption refrigeration to the scope.

[Click here to view these changes in full](#)

Send comments (with copy to [psa@ansi.org](mailto:psa@ansi.org)) to: Eric Smith, [eric.smith@iiar.org](mailto:eric.smith@iiar.org)

## **NSF (NSF International)**

### **New Standard**

BSR/NSF 455-2-201x (i1r3), Good Manufacturing Practices for Dietary Supplements (new standard)

This Standard is intended to define a standardized approach for auditing to determine the level of compliance of dietary supplement products to 21 CFR 111 Current Good Manufacturing Practices (GMPs) in Manufacturing, Packaging, Labeling, or Holding Operations for Dietary Supplements as well as incorporating additional retailer requirements. It refers to the requirements for GMP applicable to all dietary supplements. It will assist in the determination of adequate facilities and controls for dietary supplement manufacture with sufficient quality to ensure suitability for intended use.

[Click here to view these changes in full](#)

Send comments (with copy to [psa@ansi.org](mailto:psa@ansi.org)) to: [rbrooker@nsf.org](mailto:rbrooker@nsf.org)

## **UL (Underwriters Laboratories, Inc.)**

### **Revision**

BSR/UL 489-201X, Standard for Safety for Molded-Case Circuit Breakers, Molded-Case Switches and Circuit-Breaker Enclosures (revision of ANSI/UL 489-2016)

(7) Addition of requirements from UL 489G into UL 489.

[Click here to view these changes in full](#)

Send comments (with copy to [psa@ansi.org](mailto:psa@ansi.org)) to: Patricia Sena, (919) 549-1636, [patricia.a.sena@ul.com](mailto:patricia.a.sena@ul.com)

## **Comment Deadline: November 19, 2018**

## **AAFS (American Academy of Forensic Sciences)**

### **New Standard**

BSR/ASB Std 022-201x, Standard for Forensic DNA Analysis Training Programs (new standard)

This standard provides the general requirements for a forensic DNA laboratory's training program in DNA analysis and data interpretation.

Single copy price: Free

Obtain an electronic copy from: <http://asb.aafs.org/>

Document will be provided electronically on AAFS Standards Board website free of charge

Send comments (with copy to [psa@ansi.org](mailto:psa@ansi.org)) to: [asb@aaafs.org](mailto:asb@aaafs.org). This is a public comment period for a recirculation. Updated document, redline version, and comments can be viewed on the AAFS Standards Board website at: <https://asb.aafs.org/notification-of-standard-development-and-coordination/>

BSR/ASB Std 040-201x, Standards for Forensic DNA Interpretation and Comparison Protocols (new standard)

This document describes requirements for a laboratory's DNA interpretation and comparison protocol and provides direction for its development in order to consistently produce reliable, repeatable, and reproducible interpretations and conclusions that are supported by internal validation data.

Single copy price: Free

Obtain an electronic copy from: <http://asb.aafs.org/>

Document will be provided electronically on AAFS Standards Board website free of charge

Send comments (with copy to [psa@ansi.org](mailto:psa@ansi.org)) to: [asb@aafs.org](mailto:asb@aafs.org). This is a public comment period for a recirculation. Updated document, redline version, and comments can be viewed on the AAFS Standards Board website at: <https://asb.aafs.org/notification-of-standard-development-and-coordination/>

BSR/ASB Std 077-201x, Standard for the Developmental and Internal Validation of Forensic Serological Methods (new standard)

This standard provides requirements for developmental and internal validations of forensic serological methods to evaluate body fluids, stains, or residues related to forensic investigations. This standard does not address validation of forensic DNA analysis procedures.

Single copy price: Free

Obtain an electronic copy from: <http://asb.aafs.org/>

Document will be provided electronically on AAFS Standards Board website free of charge

Send comments (with copy to [psa@ansi.org](mailto:psa@ansi.org)) to: [asb@aafs.org](mailto:asb@aafs.org). Document and comments template can be viewed on the AAFS Standards Board website at: <https://asb.aafs.org/notification-of-standard-development-and-coordination/>

## **AHRI (Air-Conditioning, Heating, and Refrigeration Institute)**

### **Revision**

BSR/AHRI Standard 1230 (I-P)-201x, Performance Rating of Variable Refrigerant Flow (VRF) Multi-Split Air-Conditioning and Heat Pump Equipment (revision of ANSI/AHRI Standard 1230-2010)

This standard covers matched Variable Refrigerant Flow (VRF) Multi-Split Air Conditioners and Multi-Split Heat Pumps using distributed refrigerant technology as defined in Section 3 of this standard. This standard applies to VRF Multi-Split Systems consisting of the following matched components: (1) Outdoor unit(s) with single or multiple compressors, at least one of which is a variable capacity compressor or has a variable speed drive on a single refrigeration circuit; (2) Indoor units that have a coil, air movement device intended for single-zone air distribution, and a temperature sensing control; and (3) a zone temperature control device. The Multi-Split Systems covered in this standard are VRF Multi-Split Systems and VRF Heat Recovery Multi-Split Systems. Included are Multi-Split, Matched System Air Conditioners and Heat Pumps. This standard applies only to electrically operated, vapor compression refrigeration systems.

Single copy price: Free

Obtain an electronic copy from: [ANSIstd@ahrinet.org](mailto:ANSIstd@ahrinet.org)

Order from: Ladan Bulookbashi, (703) 600-0327, [lbulookbashi@ahrinet.org](mailto:lbulookbashi@ahrinet.org)

Send comments (with copy to [psa@ansi.org](mailto:psa@ansi.org)) to: Same

## **ASABE (American Society of Agricultural and Biological Engineers)**

### **Revision**

BSR/ASAE S433.1 MONYEAR-201x, Loads Exerted by Free-Flowing Grain on Bins (revision and redesignation of ANSI/ASABE EP433 DEC1988 (R2015) W/Corr 1)

This standard presents methods of estimating the grain pressures within centrally loaded and unloaded bins used to store free-flowing, agricultural whole grain.

Single copy price: \$65.00

Obtain an electronic copy from: [walsh@asabe.org](mailto:walsh@asabe.org)

Order from: Jean Walsh, (269) 932-7027, [walsh@asabe.org](mailto:walsh@asabe.org)

Send comments (with copy to [psa@ansi.org](mailto:psa@ansi.org)) to: Same

## **ASHRAE (American Society of Heating, Refrigerating and Air-Conditioning Engineers, Inc.)**

### ***Withdrawal***

ANSI/ASHRAE Standard 94.2-2010, Method of Testing Thermal Storage Devices with Electrical Input and Thermal Output Based on Thermal Performance (withdrawal of ANSI/ASHRAE Standard 94.2-2010)

The purpose of this standard is to provide a standard procedure for determining the energy performance of electrically charged thermal energy storage devices used in heating systems. It is believed that this standard is no longer warranted as it has no reported use.

Single copy price: \$35.00

Obtain an electronic copy from: <http://www.ashrae.org/standards-research--technology/public-review-drafts>

Order from: [standards.section@ashrae.org](mailto:standards.section@ashrae.org)

Send comments (with copy to [psa@ansi.org](mailto:psa@ansi.org)) to: <http://www.ashrae.org/standards-research--technology/public-review-drafts>

## **ASSP (ASC A10) (American Society of Safety Professionals)**

### ***Revision***

BSR/ASSE A10.46-201x, Hearing Loss Prevention for Construction and Demolition Workers (revision and redesignation of ANSI/ASSE A10.46-2013)

This standard applies to all construction and demolition workers with potential noise exposures (continuous, intermittent and impulse) of 85 dBA and above. It is intended to help employers prevent occupational hearing loss among construction and demolition workers.

Single copy price: \$140.00

Obtain an electronic copy from: [TFisher@ASSP.Org](mailto:TFisher@ASSP.Org)

Order from: Tim Fisher, (847) 768-3411, [TFisher@ASSE.Org](mailto:TFisher@ASSE.Org)

Send comments (with copy to [psa@ansi.org](mailto:psa@ansi.org)) to: Same

## **ASSP (Safety) (American Society of Safety Professionals)**

### ***Revision***

BSR/ASSP Z10.1-201X, Occupational Health and Safety Management Systems (revision and redesignation of ANSI/ASSE Z10-2012 (R2017))

This standard defines minimum requirements for an occupational health and safety management system (OHSMS).

Single copy price: \$100.00

Obtain an electronic copy from: [TFisher@ASSP.Org](mailto:TFisher@ASSP.Org)

Order from: Tim Fisher, (847) 768-3411, [TFisher@ASSP.org](mailto:TFisher@ASSP.org)

Send comments (with copy to [psa@ansi.org](mailto:psa@ansi.org)) to: Same

## **ASTM (ASTM International)**

### ***New Standard***

BSR/ASTM D2949-201x, Specification for 3.25-in. Outside Diameter Poly(Vinyl Chloride) (PVC) Plastic Drain, Waste, and Vent Pipe and Fittings (new standard)

[http://www.astm.org/ANSI\\_SA](http://www.astm.org/ANSI_SA)

Single copy price: Free

Obtain an electronic copy from: [cleonard@astm.org](mailto:cleonard@astm.org)

Order from: Corice Leonard, (610) 832-9744, [accreditation@astm.org](mailto:accreditation@astm.org)

Send comments (with copy to [psa@ansi.org](mailto:psa@ansi.org)) to: Same

BSR/ASTM F2968-201x, Specification for Black Crosslinked Polyethylene (PEX) Pipe, Fittings and Joints For Gas Distribution Applications (new standard)

[http://www.astm.org/ANSI\\_SA](http://www.astm.org/ANSI_SA)

Single copy price: Free

Obtain an electronic copy from: [cleonard@astm.org](mailto:cleonard@astm.org)

Order from: Corice Leonard, (610) 832-9744, [accreditation@astm.org](mailto:accreditation@astm.org)

Send comments (with copy to [psa@ansi.org](mailto:psa@ansi.org)) to: Same

BSR/ASTM WK30656-201x, Test Method for Determining the Fire-Test Response Characteristics of Spandrel-Panel Assemblies Due to External Spread of Fire (new standard)

[http://www.astm.org/ANSI\\_SA](http://www.astm.org/ANSI_SA)

Single copy price: Free

Obtain an electronic copy from: [cleonard@astm.org](mailto:cleonard@astm.org)

Order from: Corice Leonard, (610) 832-9744, [accreditation@astm.org](mailto:accreditation@astm.org)

Send comments (with copy to [psa@ansi.org](mailto:psa@ansi.org)) to: Same

BSR/ASTM WK44075-201x, Practice for Preparing a Occupant Exposure Screening Report (OESR) for Substances in Installed Building Product (new standard)

[http://www.astm.org/ANSI\\_SA](http://www.astm.org/ANSI_SA)

Single copy price: Free

Obtain an electronic copy from: [cleonard@astm.org](mailto:cleonard@astm.org)

Order from: Corice Leonard, (610) 832-9744, [accreditation@astm.org](mailto:accreditation@astm.org)

Send comments (with copy to [psa@ansi.org](mailto:psa@ansi.org)) to: Same

BSR/ASTM WK44130-201x, Specification for Standard Specification for Solid Wall Poly(Vinyl Chloride) (PVC) Fittings for Joining Corrugated Wall High Density Polyethylene (PE) and Polypropylene (PP) Piping (new standard)

[http://www.astm.org/ANSI\\_SA](http://www.astm.org/ANSI_SA)

Single copy price: Free

Obtain an electronic copy from: [cleonard@astm.org](mailto:cleonard@astm.org)

Order from: Corice Leonard, (610) 832-9744, [accreditation@astm.org](mailto:accreditation@astm.org)

Send comments (with copy to [psa@ansi.org](mailto:psa@ansi.org)) to: Same

BSR/ASTM WK52522-201x, Guide for Evaluating Test Method Capability and Fitness for Use (new standard)

[http://www.astm.org/ANSI\\_SA](http://www.astm.org/ANSI_SA)

Single copy price: Free

Obtain an electronic copy from: [cleonard@astm.org](mailto:cleonard@astm.org)

Order from: Corice Leonard, (610) 832-9744, [accreditation@astm.org](mailto:accreditation@astm.org)

Send comments (with copy to [psa@ansi.org](mailto:psa@ansi.org)) to: Same

BSR/ASTM WK60062-201x, Specification for Polyethylene of Raised Temperature/Aluminum/Polyethylene of Raised Temperature (PE-RT/AL/PE-RT) Composite Pressure Pipe (new standard)

[http://www.astm.org/ANSI\\_SA](http://www.astm.org/ANSI_SA)

Single copy price: Free

Obtain an electronic copy from: [cleonard@astm.org](mailto:cleonard@astm.org)

Order from: Corice Leonard, (610) 832-9744, [accreditation@astm.org](mailto:accreditation@astm.org)

Send comments (with copy to [psa@ansi.org](mailto:psa@ansi.org)) to: Same

BSR/ASTM WK61006-201x, Guide for Design Guidance for Shipboard Use of Lithium-Based Batteries (new standard)

[http://www.astm.org/ANSI\\_SA](http://www.astm.org/ANSI_SA)

Single copy price: Free

Obtain an electronic copy from: [cleonard@astm.org](mailto:cleonard@astm.org)

Order from: Corice Leonard, (610) 832-9744, [accreditation@astm.org](mailto:accreditation@astm.org)

Send comments (with copy to [psa@ansi.org](mailto:psa@ansi.org)) to: Same

BSR/ASTM WK61767-201x, Test Method for Measurement of Impurities in Graphite by Electrothermal Vaporization Inductively Coupled Plasma Optical Emission Spectrometry (ETV-ICP OES) (new standard)

[http://www.astm.org/ANSI\\_SA](http://www.astm.org/ANSI_SA)

Single copy price: Free

Obtain an electronic copy from: [cleonard@astm.org](mailto:cleonard@astm.org)

Order from: Corice Leonard, (610) 832-9744, [accreditation@astm.org](mailto:accreditation@astm.org)

Send comments (with copy to [psa@ansi.org](mailto:psa@ansi.org)) to: Same

BSR/ASTM WK62587-201x, Specification for Metal Press Insert Fittings with Factory Assembled Stainless Steel Press Sleeve for SDR9 Cross-Linked Polyethylene (PEX) Tubing (new standard)

[http://www.astm.org/ANSI\\_SA](http://www.astm.org/ANSI_SA)

Single copy price: Free

Obtain an electronic copy from: [cleonard@astm.org](mailto:cleonard@astm.org)

Order from: Corice Leonard, (610) 832-9744, [accreditation@astm.org](mailto:accreditation@astm.org)

Send comments (with copy to [psa@ansi.org](mailto:psa@ansi.org)) to: Same

BSR/ASTM WK62588-201x, Specification for Plastic Press Insert Fittings with Factory Assembled Stainless Steel Press Sleeve for SDR9 Cross-Linked Polyethylene (PEX) Tubing (new standard)

[http://www.astm.org/ANSI\\_SA](http://www.astm.org/ANSI_SA)

Single copy price: Free

Obtain an electronic copy from: [cleonard@astm.org](mailto:cleonard@astm.org)

Order from: Corice Leonard, (610) 832-9744, [accreditation@astm.org](mailto:accreditation@astm.org)

Send comments (with copy to [psa@ansi.org](mailto:psa@ansi.org)) to: Same

BSR/ASTM WK63871-201x, Test Method for Playground Surface Impact Testing in a Lab at a Specified Test Height (new standard)

[http://www.astm.org/ANSI\\_SA](http://www.astm.org/ANSI_SA)

Single copy price: Free

Obtain an electronic copy from: [cleonard@astm.org](mailto:cleonard@astm.org)

Order from: Corice Leonard, (610) 832-9744, [accreditation@astm.org](mailto:accreditation@astm.org)

Send comments (with copy to [psa@ansi.org](mailto:psa@ansi.org)) to: Same

## **ASTM (ASTM International)**

### ***Reaffirmation***

BSR/ASTM D2276-2006 (R201x), Test Method for Particulate Contaminant in Aviation Fuel by Line Sampling (reaffirmation of ANSI/ASTM D2276-2006 (R2014))

[http://www.astm.org/ANSI\\_SA](http://www.astm.org/ANSI_SA)

Single copy price: Free

Obtain an electronic copy from: [cleonard@astm.org](mailto:cleonard@astm.org)

Order from: Corice Leonard, (610) 832-9744, [accreditation@astm.org](mailto:accreditation@astm.org)

Send comments (with copy to [psa@ansi.org](mailto:psa@ansi.org)) to: Same

BSR/ASTM D3948-2014 (R201x), Test Method for Determining Water Separation Characteristics of Aviation Turbine Fuels by Portable Separometer (reaffirmation of ANSI/ASTM D3948-2014)

[http://www.astm.org/ANSI\\_SA](http://www.astm.org/ANSI_SA)

Single copy price: Free

Obtain an electronic copy from: [cleonard@astm.org](mailto:cleonard@astm.org)

Order from: Corice Leonard, (610) 832-9744, [accreditation@astm.org](mailto:accreditation@astm.org)

Send comments (with copy to [psa@ansi.org](mailto:psa@ansi.org)) to: Same

BSR/ASTM D5452-2012 (R201x), Test Method for Particulate Contamination in Aviation Fuels by Laboratory Filtration (reaffirmation of ANSI/ASTM D5452-2012)

[http://www.astm.org/ANSI\\_SA](http://www.astm.org/ANSI_SA)

Single copy price: Free

Obtain an electronic copy from: [cleonard@astm.org](mailto:cleonard@astm.org)

Order from: Corice Leonard, (610) 832-9744, [accreditation@astm.org](mailto:accreditation@astm.org)

Send comments (with copy to [psa@ansi.org](mailto:psa@ansi.org)) to: Same



BSR/ASTM D6824-2013 (R201x), Test Method for Determining Filterability of Aviation Turbine Fuel (reaffirmation of ANSI/ASTM D6824-2013)

[http://www.astm.org/ANSI\\_SA](http://www.astm.org/ANSI_SA)

Single copy price: Free

Obtain an electronic copy from: [cleonard@astm.org](mailto:cleonard@astm.org)

Order from: Corice Leonard, (610) 832-9744, [accreditation@astm.org](mailto:accreditation@astm.org)

Send comments (with copy to [psa@ansi.org](mailto:psa@ansi.org)) to: Same

BSR/ASTM D7224-2014 (R201x), Test Method for Determining Water Separation Characteristics of Kerosine-Type Aviation Turbine Fuels Containing Additives by Portable Separometer (reaffirmation of ANSI/ASTM D7224-2014)

[http://www.astm.org/ANSI\\_SA](http://www.astm.org/ANSI_SA)

Single copy price: Free

Obtain an electronic copy from: [cleonard@astm.org](mailto:cleonard@astm.org)

Order from: Corice Leonard, (610) 832-9744, [accreditation@astm.org](mailto:accreditation@astm.org)

Send comments (with copy to [psa@ansi.org](mailto:psa@ansi.org)) to: Same

BSR/ASTM D7872-2013 (R201x), Test Method for Determining the Concentration of Pipeline Drag Reducer Additive in Aviation Turbine Fuels (reaffirmation of ANSI/ASTM D7872-2013)

[http://www.astm.org/ANSI\\_SA](http://www.astm.org/ANSI_SA)

Single copy price: Free

Obtain an electronic copy from: [cleonard@astm.org](mailto:cleonard@astm.org)

Order from: Corice Leonard, (610) 832-9744, [accreditation@astm.org](mailto:accreditation@astm.org)

Send comments (with copy to [psa@ansi.org](mailto:psa@ansi.org)) to: Same

BSR/ASTM E696-2017 (R201x), Specification for Tungsten-Rhenium Alloy Thermocouple Wire (reaffirmation of ANSI/ASTM E696-2017)

[http://www.astm.org/ANSI\\_SA](http://www.astm.org/ANSI_SA)

Single copy price: Free

Obtain an electronic copy from: [cleonard@astm.org](mailto:cleonard@astm.org)

Order from: Corice Leonard, (610) 832-9744, [accreditation@astm.org](mailto:accreditation@astm.org)

Send comments (with copy to [psa@ansi.org](mailto:psa@ansi.org)) to: Same

BSR/ASTM E1402-2013 (R201x), Guide for Sampling Design (reaffirmation of ANSI/ASTM E1402-2013)

[http://www.astm.org/ANSI\\_SA](http://www.astm.org/ANSI_SA)

Single copy price: Free

Obtain an electronic copy from: [cleonard@astm.org](mailto:cleonard@astm.org)

Order from: Corice Leonard, (610) 832-9744, [accreditation@astm.org](mailto:accreditation@astm.org)

Send comments (with copy to [psa@ansi.org](mailto:psa@ansi.org)) to: Same

BSR/ASTM E2696-2009 (R201x), Practice for Life and Reliability Testing Based on the Exponential Distribution (reaffirmation of ANSI/ASTM E2696-2009 (R2013))

[http://www.astm.org/ANSI\\_SA](http://www.astm.org/ANSI_SA)

Single copy price: Free

Obtain an electronic copy from: [cleonard@astm.org](mailto:cleonard@astm.org)

Order from: Corice Leonard, (610) 832-9744, [accreditation@astm.org](mailto:accreditation@astm.org)

Send comments (with copy to [psa@ansi.org](mailto:psa@ansi.org)) to: Same

BSR/ASTM F659-2010 (R201x), Specification for Ski and Snowboard Goggles (reaffirmation of ANSI/ASTM F659-2010)

[http://www.astm.org/ANSI\\_SA](http://www.astm.org/ANSI_SA)

Single copy price: Free

Obtain an electronic copy from: [cleonard@astm.org](mailto:cleonard@astm.org)

Order from: Corice Leonard, (610) 832-9744, [accreditation@astm.org](mailto:accreditation@astm.org)

Send comments (with copy to [psa@ansi.org](mailto:psa@ansi.org)) to: Same

BSR/ASTM F2043-2013 (R201x), Classification for Bicycle Usage (reaffirmation of ANSI/ASTM F2043-2013)

[http://www.astm.org/ANSI\\_SA](http://www.astm.org/ANSI_SA)

Single copy price: Free

Obtain an electronic copy from: [cleonard@astm.org](mailto:cleonard@astm.org)

Order from: Corice Leonard, (610) 832-9744, [accreditation@astm.org](mailto:accreditation@astm.org)

Send comments (with copy to [psa@ansi.org](mailto:psa@ansi.org)) to: Same

BSR/ASTM F2983-2013 (R201x), Guide for Manufacturers for Labeling and Care Instructions for Wrestling Mats (reaffirmation of ANSI/ASTM F2983-2013)

[http://www.astm.org/ANSI\\_SA](http://www.astm.org/ANSI_SA)

Single copy price: Free

Obtain an electronic copy from: [cleonard@astm.org](mailto:cleonard@astm.org)

Order from: Corice Leonard, (610) 832-9744, [accreditation@astm.org](mailto:accreditation@astm.org)

Send comments (with copy to [psa@ansi.org](mailto:psa@ansi.org)) to: Same

## **ASTM (ASTM International)**

### ***Revision***

BSR/ASTM C781-201x, Practice for Testing Graphite and Boronated Graphite Materials for High-Temperature Gas-Cooled Nuclear Reactor Components (revision of ANSI/ASTM C781-2008 (R2014))

[http://www.astm.org/ANSI\\_SA](http://www.astm.org/ANSI_SA)

Single copy price: Free

Obtain an electronic copy from: [cleonard@astm.org](mailto:cleonard@astm.org)

Order from: Corice Leonard, (610) 832-9744, [accreditation@astm.org](mailto:accreditation@astm.org)

Send comments (with copy to [psa@ansi.org](mailto:psa@ansi.org)) to: Same

BSR/ASTM D2846-201x, Specification for Chlorinated Poly(Vinyl Chloride) (CPVC) Plastic Hot- and Cold-Water Distribution Systems (revision of ANSI/ASTM D2846-2017)

[http://www.astm.org/ANSI\\_SA](http://www.astm.org/ANSI_SA)

Single copy price: Free

Obtain an electronic copy from: [cleonard@astm.org](mailto:cleonard@astm.org)

Order from: Corice Leonard, (610) 832-9744, [accreditation@astm.org](mailto:accreditation@astm.org)

Send comments (with copy to [psa@ansi.org](mailto:psa@ansi.org)) to: Same

BSR/ASTM D3244-201x, Practice for Utilization of Test Data to Determine Conformance with Specifications (revision of ANSI/ASTM D3244-2016)

[http://www.astm.org/ANSI\\_SA](http://www.astm.org/ANSI_SA)

Single copy price: Free

Obtain an electronic copy from: [cleonard@astm.org](mailto:cleonard@astm.org)

Order from: Corice Leonard, (610) 832-9744, [accreditation@astm.org](mailto:accreditation@astm.org)

Send comments (with copy to [psa@ansi.org](mailto:psa@ansi.org)) to: Same

BSR/ASTM D3753-201x, Specification for Glass-Fiber-Reinforced Polyester Manholes and Wetwells (revision of ANSI/ASTM D3753-2012)

[http://www.astm.org/ANSI\\_SA](http://www.astm.org/ANSI_SA)

Single copy price: Free

Obtain an electronic copy from: [cleonard@astm.org](mailto:cleonard@astm.org)

Order from: Corice Leonard, (610) 832-9744, [accreditation@astm.org](mailto:accreditation@astm.org)

Send comments (with copy to [psa@ansi.org](mailto:psa@ansi.org)) to: Same

BSR/ASTM D5685-201x, Specification for Fiberglass (Glass-Fiber-Reinforced Thermosetting-Resin) Pressure Pipe Fittings (revision of ANSI/ASTM D5685-2011)

[http://www.astm.org/ANSI\\_SA](http://www.astm.org/ANSI_SA)

Single copy price: Free

Obtain an electronic copy from: [cleonard@astm.org](mailto:cleonard@astm.org)

Order from: Corice Leonard, (610) 832-9744, [accreditation@astm.org](mailto:accreditation@astm.org)

Send comments (with copy to [psa@ansi.org](mailto:psa@ansi.org)) to: Same

BSR/ASTM D6041-201x, Specification for Contact-Molded Fiberglass (Glass-Fiber-Reinforced Thermosetting Resin) Corrosion Resistant Pipe and Fittings (revision of ANSI/ASTM D6041-2012)

[http://www.astm.org/ANSI\\_SA](http://www.astm.org/ANSI_SA)

Single copy price: Free

Obtain an electronic copy from: [cleonard@astm.org](mailto:cleonard@astm.org)

Order from: Corice Leonard, (610) 832-9744, [accreditation@astm.org](mailto:accreditation@astm.org)

Send comments (with copy to [psa@ansi.org](mailto:psa@ansi.org)) to: Same

BSR/ASTM D6227-201x, Specification for Unleaded Aviation Gasoline Containing a Non-hydrocarbon Component (revision of ANSI/ASTM D6227-2017)

[http://www.astm.org/ANSI\\_SA](http://www.astm.org/ANSI_SA)

Single copy price: Free

Obtain an electronic copy from: [cleonard@astm.org](mailto:cleonard@astm.org)

Order from: Corice Leonard, (610) 832-9744, [accreditation@astm.org](mailto:accreditation@astm.org)

Send comments (with copy to [psa@ansi.org](mailto:psa@ansi.org)) to: Same

BSR/ASTM D7547-201x, Specification for Hydrocarbon Unleaded Aviation Gasoline (revision of ANSI/ASTM D7547-2018)

[http://www.astm.org/ANSI\\_SA](http://www.astm.org/ANSI_SA)

Single copy price: Free

Obtain an electronic copy from: [cleonard@astm.org](mailto:cleonard@astm.org)

Order from: Corice Leonard, (610) 832-9744, [accreditation@astm.org](mailto:accreditation@astm.org)

Send comments (with copy to [psa@ansi.org](mailto:psa@ansi.org)) to: Same

BSR/ASTM D7719-201x, Specification for High Aromatic Content Unleaded Hydrocarbon Aviation Gasoline (revision of ANSI/ASTM D7719-2017)

[http://www.astm.org/ANSI\\_SA](http://www.astm.org/ANSI_SA)

Single copy price: Free

Obtain an electronic copy from: [cleonard@astm.org](mailto:cleonard@astm.org)

Order from: Corice Leonard, (610) 832-9744, [accreditation@astm.org](mailto:accreditation@astm.org)

Send comments (with copy to [psa@ansi.org](mailto:psa@ansi.org)) to: Same

BSR/ASTM D7960-201x, Specification for Unleaded Aviation Gasoline Test Fuel Containing Non-Hydrocarbon Components (revision of ANSI/ASTM D7960-2017)

[http://www.astm.org/ANSI\\_SA](http://www.astm.org/ANSI_SA)

Single copy price: Free

Obtain an electronic copy from: [cleonard@astm.org](mailto:cleonard@astm.org)

Order from: Corice Leonard, (610) 832-9744, [accreditation@astm.org](mailto:accreditation@astm.org)

Send comments (with copy to [psa@ansi.org](mailto:psa@ansi.org)) to: Same

BSR/ASTM E84-201x, Test Method for Surface Burning Characteristics of Building Materials (revision of ANSI/ASTM E84-2018)

[http://www.astm.org/ANSI\\_SA](http://www.astm.org/ANSI_SA)

Single copy price: Free

Obtain an electronic copy from: [cleonard@astm.org](mailto:cleonard@astm.org)

Order from: Corice Leonard, (610) 832-9744, [accreditation@astm.org](mailto:accreditation@astm.org)

Send comments (with copy to [psa@ansi.org](mailto:psa@ansi.org)) to: Same

BSR/ASTM E119-201x, Test Methods for Fire Tests of Building Construction and Materials (revision of ANSI/ASTM E119-2018)

[http://www.astm.org/ANSI\\_SA](http://www.astm.org/ANSI_SA)

Single copy price: Free

Obtain an electronic copy from: [cleonard@astm.org](mailto:cleonard@astm.org)

Order from: Corice Leonard, (610) 832-9744, [accreditation@astm.org](mailto:accreditation@astm.org)

Send comments (with copy to [psa@ansi.org](mailto:psa@ansi.org)) to: Same

BSR/ASTM E136-201x, Test Method for Behavior of Materials in a Vertical Tube Furnace at 750C (revision of ANSI/ASTM E136-2016)

[http://www.astm.org/ANSI\\_SA](http://www.astm.org/ANSI_SA)

Single copy price: Free

Obtain an electronic copy from: [cleonard@astm.org](mailto:cleonard@astm.org)

Order from: Corice Leonard, (610) 832-9744, [accreditation@astm.org](mailto:accreditation@astm.org)

Send comments (with copy to [psa@ansi.org](mailto:psa@ansi.org)) to: Same

BSR/ASTM E176-201x, Terminology of Fire Standards (revision of ANSI/ASTM E176-2018)

[http://www.astm.org/ANSI\\_SA](http://www.astm.org/ANSI_SA)

Single copy price: Free

Obtain an electronic copy from: [cleonard@astm.org](mailto:cleonard@astm.org)

Order from: Corice Leonard, (610) 832-9744, [accreditation@astm.org](mailto:accreditation@astm.org)

Send comments (with copy to [psa@ansi.org](mailto:psa@ansi.org)) to: Same

BSR/ASTM E535-201x, Practice for Preparation of Fire-Test-Response Standards (revision of ANSI/ASTM E535-2014)

[http://www.astm.org/ANSI\\_SA](http://www.astm.org/ANSI_SA)

Single copy price: Free

Obtain an electronic copy from: [cleonard@astm.org](mailto:cleonard@astm.org)

Order from: Corice Leonard, (610) 832-9744, [accreditation@astm.org](mailto:accreditation@astm.org)

Send comments (with copy to [psa@ansi.org](mailto:psa@ansi.org)) to: Same

BSR/ASTM E927-201x, Specification for Solar Simulation for Photovoltaic Testing (revision of ANSI/ASTM E927-2010 (2015))

[http://www.astm.org/ANSI\\_SA](http://www.astm.org/ANSI_SA)

Single copy price: Free

Obtain an electronic copy from: [cleonard@astm.org](mailto:cleonard@astm.org)

Order from: Corice Leonard, (610) 832-9744, [accreditation@astm.org](mailto:accreditation@astm.org)

Send comments (with copy to [psa@ansi.org](mailto:psa@ansi.org)) to: Same

BSR/ASTM E1317-201x, Test Method for Flammability of Marine Surface Finishes (revision of ANSI/ASTM E1317-2012)

[http://www.astm.org/ANSI\\_SA](http://www.astm.org/ANSI_SA)

Single copy price: Free

Obtain an electronic copy from: [cleonard@astm.org](mailto:cleonard@astm.org)

Order from: Corice Leonard, (610) 832-9744, [accreditation@astm.org](mailto:accreditation@astm.org)

Send comments (with copy to [psa@ansi.org](mailto:psa@ansi.org)) to: Same

BSR/ASTM E1321-201x, Test Method for Determining Material Ignition and Flame Spread Properties (revision of ANSI/ASTM E1321-2013)

[http://www.astm.org/ANSI\\_SA](http://www.astm.org/ANSI_SA)

Single copy price: Free

Obtain an electronic copy from: [cleonard@astm.org](mailto:cleonard@astm.org)

Order from: Corice Leonard, (610) 832-9744, [accreditation@astm.org](mailto:accreditation@astm.org)

Send comments (with copy to [psa@ansi.org](mailto:psa@ansi.org)) to: Same

BSR/ASTM E1995-201x, Test Method for Measurement of Smoke Obscuration Using a Conical Radiant Source in a Single Closed Chamber, with the Test Specimen Oriented Horizontally (revision of ANSI/ASTM E1995-2016)

[http://www.astm.org/ANSI\\_SA](http://www.astm.org/ANSI_SA)

Single copy price: Free

Obtain an electronic copy from: [cleonard@astm.org](mailto:cleonard@astm.org)

Order from: Corice Leonard, (610) 832-9744, [accreditation@astm.org](mailto:accreditation@astm.org)

Send comments (with copy to [psa@ansi.org](mailto:psa@ansi.org)) to: Same

BSR/ASTM E2586-201x, Practice for Calculating and Using Basic Statistics (revision of ANSI/ASTM E2586-2018)

[http://www.astm.org/ANSI\\_SA](http://www.astm.org/ANSI_SA)

Single copy price: Free

Obtain an electronic copy from: [cleonard@astm.org](mailto:cleonard@astm.org)

Order from: Corice Leonard, (610) 832-9744, [accreditation@astm.org](mailto:accreditation@astm.org)

Send comments (with copy to [psa@ansi.org](mailto:psa@ansi.org)) to: Same

BSR/ASTM E2652-201x, Test Method for Behavior of Materials in a Tube Furnace with a Cone-shaped Airflow Stabilizer, at 750C (revision of ANSI/ASTM E2652-2016)

[http://www.astm.org/ANSI\\_SA](http://www.astm.org/ANSI_SA)

Single copy price: Free

Obtain an electronic copy from: [cleonard@astm.org](mailto:cleonard@astm.org)

Order from: Corice Leonard, (610) 832-9744, [accreditation@astm.org](mailto:accreditation@astm.org)

Send comments (with copy to [psa@ansi.org](mailto:psa@ansi.org)) to: Same

BSR/ASTM E2816-201x, Test Methods for Fire Resistive Metallic HVAC Duct Systems (revision of ANSI/ASTM E2816-2018)

[http://www.astm.org/ANSI\\_SA](http://www.astm.org/ANSI_SA)

Single copy price: Free

Obtain an electronic copy from: [cleonard@astm.org](mailto:cleonard@astm.org)

Order from: Corice Leonard, (610) 832-9744, [accreditation@astm.org](mailto:accreditation@astm.org)

Send comments (with copy to [psa@ansi.org](mailto:psa@ansi.org)) to: Same

BSR/ASTM E2849-201x, Practice for Professional Certification Performance Testing (revision of ANSI/ASTM E2849-2013)

[http://www.astm.org/ANSI\\_SA](http://www.astm.org/ANSI_SA)

Single copy price: Free

Obtain an electronic copy from: [cleonard@astm.org](mailto:cleonard@astm.org)

Order from: Corice Leonard, (610) 832-9744, [accreditation@astm.org](mailto:accreditation@astm.org)

Send comments (with copy to [psa@ansi.org](mailto:psa@ansi.org)) to: Same

BSR/ASTM E2989-201x, Guide for Assessment of Continued Applicability of Fire Test Reports Used in Building Regulation (revision of ANSI/ASTM E2989-2015)

[http://www.astm.org/ANSI\\_SA](http://www.astm.org/ANSI_SA)

Single copy price: Free

Obtain an electronic copy from: [cleonard@astm.org](mailto:cleonard@astm.org)

Order from: Corice Leonard, (610) 832-9744, [accreditation@astm.org](mailto:accreditation@astm.org)

Send comments (with copy to [psa@ansi.org](mailto:psa@ansi.org)) to: Same

BSR/ASTM E3075-201x, Test Method for Water Immersion and Drying for Evaluation of Flood Damage Resistance (revision of ANSI/ASTM E3075-2018)

[http://www.astm.org/ANSI\\_SA](http://www.astm.org/ANSI_SA)

Single copy price: Free

Obtain an electronic copy from: [cleonard@astm.org](mailto:cleonard@astm.org)

Order from: Corice Leonard, (610) 832-9744, [accreditation@astm.org](mailto:accreditation@astm.org)

Send comments (with copy to [psa@ansi.org](mailto:psa@ansi.org)) to: Same

BSR/ASTM F722-201x, Specification for Welded Joints for Shipboard Piping Systems (revision of ANSI/ASTM F722-1982 (R2014))

[http://www.astm.org/ANSI\\_SA](http://www.astm.org/ANSI_SA)

Single copy price: Free

Obtain an electronic copy from: [cleonard@astm.org](mailto:cleonard@astm.org)

Order from: Corice Leonard, (610) 832-9744, [accreditation@astm.org](mailto:accreditation@astm.org)

Send comments (with copy to [psa@ansi.org](mailto:psa@ansi.org)) to: Same

BSR/ASTM F1292-201x, Specification for Impact Attenuation of Surfacing Materials within the Use Zone of Playground Equipment (revision of ANSI/ASTM F1292-2017)

[http://www.astm.org/ANSI\\_SA](http://www.astm.org/ANSI_SA)

Single copy price: Free

Obtain an electronic copy from: [cleonard@astm.org](mailto:cleonard@astm.org)

Order from: Corice Leonard, (610) 832-9744, [accreditation@astm.org](mailto:accreditation@astm.org)

Send comments (with copy to [psa@ansi.org](mailto:psa@ansi.org)) to: Same

BSR/ASTM F1312-201x, Specification for Brick, Insulating, High Temperature, Fire Clay (revision of ANSI/ASTM F1312-90 (R2013))

[http://www.astm.org/ANSI\\_SA](http://www.astm.org/ANSI_SA)

Single copy price: Free

Obtain an electronic copy from: [cleonard@astm.org](mailto:cleonard@astm.org)

Order from: Corice Leonard, (610) 832-9744, [accreditation@astm.org](mailto:accreditation@astm.org)

Send comments (with copy to [psa@ansi.org](mailto:psa@ansi.org)) to: Same

BSR/ASTM F1674-201x, Test Method for Joint Restraint Products for Use with PVC Pipe (revision of ANSI/ASTM F1674-2017)

[http://www.astm.org/ANSI\\_SA](http://www.astm.org/ANSI_SA)

Single copy price: Free

Obtain an electronic copy from: [cleonard@astm.org](mailto:cleonard@astm.org)

Order from: Corice Leonard, (610) 832-9744, [accreditation@astm.org](mailto:accreditation@astm.org)

Send comments (with copy to [psa@ansi.org](mailto:psa@ansi.org)) to: Same

BSR/ASTM F1807-201x, Specification for Metal Insert Fittings Utilizing a Copper Crimp Ring for SDR9 Cross-Linked Polyethylene (PEX) Tubing and SDR9 Polyethylene of Raised Temperature (PE-RT) Tubing (revision of ANSI/ASTM F1807-2018)

[http://www.astm.org/ANSI\\_SA](http://www.astm.org/ANSI_SA)

Single copy price: Free

Obtain an electronic copy from: [cleonard@astm.org](mailto:cleonard@astm.org)

Order from: Corice Leonard, (610) 832-9744, [accreditation@astm.org](mailto:accreditation@astm.org)

Send comments (with copy to [psa@ansi.org](mailto:psa@ansi.org)) to: Same

BSR/ASTM F1882-201x, Specification for Residential Basketball Systems (revision of ANSI/ASTM F1882-2015)

[http://www.astm.org/ANSI\\_SA](http://www.astm.org/ANSI_SA)

Single copy price: Free

Obtain an electronic copy from: [cleonard@astm.org](mailto:cleonard@astm.org)

Order from: Corice Leonard, (610) 832-9744, [accreditation@astm.org](mailto:accreditation@astm.org)

Send comments (with copy to [psa@ansi.org](mailto:psa@ansi.org)) to: Same

BSR/ASTM F1960-201x, Specification for Cold Expansion Fittings with PEX Reinforcing Rings for Use with Cross-Linked Polyethylene (PEX) Tubing (revision of ANSI/ASTM F1960-2017)

[http://www.astm.org/ANSI\\_SA](http://www.astm.org/ANSI_SA)

Single copy price: Free

Obtain an electronic copy from: [cleonard@astm.org](mailto:cleonard@astm.org)

Order from: Corice Leonard, (610) 832-9744, [accreditation@astm.org](mailto:accreditation@astm.org)

Send comments (with copy to [psa@ansi.org](mailto:psa@ansi.org)) to: Same

BSR/ASTM F2080-201x, Specification for Cold-Expansion Fittings with Metal Compression-Sleeves for Crosslinked Polyethylene (PEX) Pipe and SDR9 Polyethylene of Raised Temperature (PE-RT) Pipe (revision of ANSI/ASTM F2080-2016)

[http://www.astm.org/ANSI\\_SA](http://www.astm.org/ANSI_SA)

Single copy price: Free

Obtain an electronic copy from: [cleonard@astm.org](mailto:cleonard@astm.org)

Order from: Corice Leonard, (610) 832-9744, [accreditation@astm.org](mailto:accreditation@astm.org)

Send comments (with copy to [psa@ansi.org](mailto:psa@ansi.org)) to: Same

BSR/ASTM F2159-201x, Specification for Plastic Insert Fittings Utilizing a Copper Crimp Ring for SDR9 Cross-Linked Polyethylene (PEX) Tubing and SDR9 Polyethylene of Raised Temperature (PE-RT) Tubing (revision of ANSI/ASTM F2159-2018)

[http://www.astm.org/ANSI\\_SA](http://www.astm.org/ANSI_SA)

Single copy price: Free

Obtain an electronic copy from: [cleonard@astm.org](mailto:cleonard@astm.org)

Order from: Corice Leonard, (610) 832-9744, [accreditation@astm.org](mailto:accreditation@astm.org)

Send comments (with copy to [psa@ansi.org](mailto:psa@ansi.org)) to: Same

BSR/ASTM F2361-201x, Guide for Ordering Low Voltage (1000 VAC or Less) Alternating Current Electric Motors for Shipboard Service Up to and Including Motors of 500 Horsepower (revision of ANSI/ASTM F2361-2009 (R2013))

[http://www.astm.org/ANSI\\_SA](http://www.astm.org/ANSI_SA)

Single copy price: Free

Obtain an electronic copy from: [cleonard@astm.org](mailto:cleonard@astm.org)

Order from: Corice Leonard, (610) 832-9744, [accreditation@astm.org](mailto:accreditation@astm.org)

Send comments (with copy to [psa@ansi.org](mailto:psa@ansi.org)) to: Same

BSR/ASTM F2434-201x, Specification for Metal Insert Fittings Utilizing a Copper Crimp Ring for SDR9 Cross-Linked Polyethylene (PEX) Tubing and SDR9 Cross-Linked Polyethylene/Aluminum/Cross-Linked Polyethylene (PEX-AL-PEX) Tubing (revision of ANSI/ASTM F2434-2017)

[http://www.astm.org/ANSI\\_SA](http://www.astm.org/ANSI_SA)

Single copy price: Free

Obtain an electronic copy from: [cleonard@astm.org](mailto:cleonard@astm.org)

Order from: Corice Leonard, (610) 832-9744, [accreditation@astm.org](mailto:accreditation@astm.org)

Send comments (with copy to [psa@ansi.org](mailto:psa@ansi.org)) to: Same

BSR/ASTM F2440-201x, Specification for Indoor Wall/Feature Padding (revision of ANSI/ASTM F2440-2011)

[http://www.astm.org/ANSI\\_SA](http://www.astm.org/ANSI_SA)

Single copy price: Free

Obtain an electronic copy from: [cleonard@astm.org](mailto:cleonard@astm.org)

Order from: Corice Leonard, (610) 832-9744, [accreditation@astm.org](mailto:accreditation@astm.org)

Send comments (with copy to [psa@ansi.org](mailto:psa@ansi.org)) to: Same

BSR/ASTM F2618-201x, Specification for Chlorinated Poly(Vinyl Chloride) (CPVC) Pipe and Fittings for Chemical Waste Drainage Systems (revision of ANSI/ASTM F2618-2017)

[http://www.astm.org/ANSI\\_SA](http://www.astm.org/ANSI_SA)

Single copy price: Free

Obtain an electronic copy from: [cleonard@astm.org](mailto:cleonard@astm.org)

Order from: Corice Leonard, (610) 832-9744, [accreditation@astm.org](mailto:accreditation@astm.org)

Send comments (with copy to [psa@ansi.org](mailto:psa@ansi.org)) to: Same

BSR/ASTM F2735-201x, Specification for Plastic Insert Fittings for SDR9 Cross-Linked Polyethylene (PEX) and Polyethylene of Raised Temperature (PE-RT) Tubing (revision of ANSI/ASTM F2735-2017)

[http://www.astm.org/ANSI\\_SA](http://www.astm.org/ANSI_SA)

Single copy price: Free

Obtain an electronic copy from: [cleonard@astm.org](mailto:cleonard@astm.org)

Order from: Corice Leonard, (610) 832-9744, [accreditation@astm.org](mailto:accreditation@astm.org)

Send comments (with copy to [psa@ansi.org](mailto:psa@ansi.org)) to: Same

BSR/ASTM F2829-201x, Specification for Metric- and Inch-Sized Crosslinked Polyethylene (PEX) Pipe Systems (revision of ANSI/ASTM F2829-2017)

[http://www.astm.org/ANSI\\_SA](http://www.astm.org/ANSI_SA)

Single copy price: Free

Obtain an electronic copy from: [cleonard@astm.org](mailto:cleonard@astm.org)

Order from: Corice Leonard, (610) 832-9744, [accreditation@astm.org](mailto:accreditation@astm.org)

Send comments (with copy to [psa@ansi.org](mailto:psa@ansi.org)) to: Same

BSR/ASTM F3128-201x, Specification for Poly(Vinyl Chloride) (PVC) Schedule 40 Drain, Waste, and Vent Pipe with a Cellular Core (revision of ANSI/ASTM F3128-2017)

[http://www.astm.org/ANSI\\_SA](http://www.astm.org/ANSI_SA)

Single copy price: Free

Obtain an electronic copy from: [cleonard@astm.org](mailto:cleonard@astm.org)

Order from: Corice Leonard, (610) 832-9744, [accreditation@astm.org](mailto:accreditation@astm.org)

Send comments (with copy to [psa@ansi.org](mailto:psa@ansi.org)) to: Same

BSR/ASTM F3226-201x, Specification for Metallic Press-Connect Fittings for Piping and Tubing Systems (revision of ANSI/ASTM F3226-2016)

[http://www.astm.org/ANSI\\_SA](http://www.astm.org/ANSI_SA)

Single copy price: Free

Obtain an electronic copy from: [cleonard@astm.org](mailto:cleonard@astm.org)

Order from: Corice Leonard, (610) 832-9744, [accreditation@astm.org](mailto:accreditation@astm.org)

Send comments (with copy to [psa@ansi.org](mailto:psa@ansi.org)) to: Same

## **AWS (American Welding Society)**

### ***Revision***

BSR/AWS D14.4/D14.4M-201X, Specification for the Design of Welded Joints in Machinery and Equipment (revision of ANSI/AWS D14.4/D14.4M-2012)

This specification establishes common acceptance criteria for classifying and applying carbon and low-alloy steel welded joints used in the manufacture of machines and equipment. It also covers weld joint design, workmanship, quality control requirements and procedures, weld joint inspection (visual, radiographic, ultrasonic, magnetic particle, liquid penetrant), repair of weld defects, and heat treatment.

Single copy price: \$40.50

Obtain an electronic copy from: [kbulger@aws.org](mailto:kbulger@aws.org)

Order from: Kevin Bulger, (305) 443-9353, [kbulger@aws.org](mailto:kbulger@aws.org)

Send comments (with copy to [psa@ansi.org](mailto:psa@ansi.org)) to: [adavis@aws.org](mailto:adavis@aws.org)



## **BICSI (Building Industry Consulting Service International)**

### ***New Standard***

BSR/BICSI N1-201x, Installation Practices for Telecommunications and ICT Cabling and Related Cabling Infrastructure (new standard)

This standard specifies best practices for installation of telecommunications cabling intended to support remote power. These installation practices are intended to facilitate compliance with applicable codes (e.g., National Electrical Code, Canadian Electrical Code) and to follow the recommendations and requirements of applicable standards.

Single copy price: Free

Obtain an electronic copy from: [jsilveira@bicsi.org](mailto:jsilveira@bicsi.org)

Send comments (with copy to [psa@ansi.org](mailto:psa@ansi.org)) to: [jsilveira@bicsi.org](mailto:jsilveira@bicsi.org)

## **ECIA (Electronic Components Industry Association)**

### ***New Standard***

BSR/EIA 364-119-201x, Removal Tool Rotation Test Procedure for Electrical Connectors (new standard)

This test standard establishes a test method to determine if the removal tool rotation that is used to remove a contact from a connector produces evidence of damage to the contacts, the connector insert, or the contact-retaining mechanism.

Single copy price: \$78.00

Order from: Global Engineering Documents, (800) 854-7179, [www.global.ihs.com](http://www.global.ihs.com)

Send comments (with copy to [psa@ansi.org](mailto:psa@ansi.org)) to: Ed Mikoski, [emikoski@ecianow.org](mailto:emikoski@ecianow.org)

## **ESTA (Entertainment Services and Technology Association)**

### ***Revision***

BSR/E1.53-201x, Overhead mounting of luminaires, lighting accessories, and other portable devices: Specification and practice (revision of ANSI E1.53-2016)

The standard covers specifications for the primary and secondary mounting devices for portable stage and studio luminaires and accessories, and their use. It also covers these mounting devices for special effects equipment often mounted along with lighting equipment on trusses and rigging system battens. The standard is being revised to clarify marking requirements and environmental considerations.

Single copy price: Free

Obtain an electronic copy from: [http://tsp.esta.org/tsp/documents/public\\_review\\_docs.php](http://tsp.esta.org/tsp/documents/public_review_docs.php)

Order from: [standards@esta.org](mailto:standards@esta.org)

Send comments (with copy to [psa@ansi.org](mailto:psa@ansi.org)) to: ESTA Standards Manager, [standards@esta.org](mailto:standards@esta.org)

## **IAPMO (ASSE Chapter) (ASSE International Chapter of IAPMO)**

### ***Revision***

BSR/ASSE Series 6000-201x, Professional Qualifications Standard for Medical Gas Systems Personnel (revision of ANSI/ASSE Series 6000-2015)

This standard establishes uniform minimum requirements for qualified Medical Gas Systems Installers, Inspectors, Verifiers, Maintenance Personnel, and Instructors as well as for qualified Bulk Medical Gas/Cryogenic Fluid Central Supply Systems Installers, Inspectors, Verifiers, and Instructors.

Single copy price: Free

Obtain an electronic copy from: [marianne.waickman@asse-plumbing.org](mailto:marianne.waickman@asse-plumbing.org)

Order from: Marianne Waickman, 708-995-3015 or [marianne.waickman@asse-plumbing.org](mailto:marianne.waickman@asse-plumbing.org)

Send comments (with copy to [psa@ansi.org](mailto:psa@ansi.org)) to: Same

## **NCPDP (National Council for Prescription Drug Programs)**

### ***Revision***

BSR/NCPDP Prescription Transfer Standard v37-201x, NCPDP Prescription Transfer Standard v37 (revision and redesignation of ANSI/NCPDP Prescription Transfer Standard v36-2017)

The basic function of the Prescription Transfer Standard is to be able to transfer prescription data in a standardized layout. Two layouts, a fixed length and a variable length format, were developed to provide more flexibility in the amount of data that needs to be transferred without making it a requirement in all cases. Both layouts include data elements required for the transfer of prescription data.

Single copy price: \$200.00 (non-member)

Obtain an electronic copy from: [kkrempin@ncdpd.org](mailto:kkrempin@ncdpd.org)

Send comments (with copy to [psa@ansi.org](mailto:psa@ansi.org)) to: [kkrempin@ncdpd.org](mailto:kkrempin@ncdpd.org)

## **NEMA (ASC C78) (National Electrical Manufacturers Association)**

### ***New Standard***

BSR C78.54-201X, Standard for Electric Lamps - Specification Sheet for Tubular Fluorescent Replacement and Retrofit LED Lamps (new standard)

The purpose is to standardize the Tubular LED (TLED) Lamp specification sheet, or data reporting format, as the means of communication of critical lamp characteristics such as:

- intended use ballasts (if applicable);
- reference circuit (if applicable); and
- identify input voltage requirements (for use with mains voltage).

Other characteristics may include physical dimensions and/or temperature ratings for operation. This standard will cover all types of fluorescent replacement and retrofit TLED systems. The minimum defined contents and format of the specification sheet will be provided. Manufacturers can include additional information.

Single copy price: \$100.00

Obtain an electronic copy from: [michael.erbesfeld@nema.org](mailto:michael.erbesfeld@nema.org)

Order from: Michael Erbesfeld, 703-841-3262, [Michael.Erbesfeld@nema.org](mailto:Michael.Erbesfeld@nema.org)

Send comments (with copy to [psa@ansi.org](mailto:psa@ansi.org)) to: Same

## **NEMA (ASC ESS) (National Electrical Manufacturers Association)**

### ***New Standard***

BSR/ESS 1-201x, Protocol for Uniformly Measuring and Expressing the Performance of Energy Storage Systems (new standard)

Enables a more informed manner of considering the performance of energy storage systems and provides a platform for more comparable consideration of system options.

Single copy price: \$92.00

Order from: Brian Marchionini, (703) 841-3279, [Brian.Marchionini@nema.org](mailto:Brian.Marchionini@nema.org)

Send comments (with copy to [psa@ansi.org](mailto:psa@ansi.org)) to: Same

## **NFPA (National Fire Protection Association)**

**The National Fire Protection Association announces the availability of the Fall 2019 First Draft Reports for concurrent review and comment by NFPA and ANSI.**

The First Draft Reports contain the disposition of public inputs that were received for the Fall 2019 NFPA Standards. The First Draft Reports for the Fall 2019 NFPA Standards can be found on the document's specific URL, [www.nfpa.org/doc#next](http://www.nfpa.org/doc#next) (for example [www.nfpa.org/78next](http://www.nfpa.org/78next)). All comments on the Fall 2019 First Draft Reports must be received by November 15, 2018. The disposition of all comments received from the review of the First Draft Reports will be published in the Second Draft Report, and will also be available on the document's information page under the next edition tab. For more information on the rules and for up-to-date information on schedules and deadlines for processing NFPA Documents, check the NFPA website at <http://www.nfpa.org> or contact NFPA's Codes and Standards Administration, at NFPA, One Batterymarch Park, Quincy, MA, 02269-7471. Those who submit comments to NFPA's online submission system on the Fall 2019 NFPA Standards are invited to copy ANSI's Board of Standards Review.

### **Revision**

BSR/NFPA 56-201x, Standard for Fire and Explosion Prevention during Cleaning and Purging of Flammable Gas Piping Systems (revision of ANSI/NFPA 56-2017)

This standard shall apply to fire and explosion prevention during cleaning and purging activities for new and existing flammable gas piping found in electric-generating plants and in industrial, institutional, and commercial applications. Coverage of fuel gas piping systems shall extend from the point of delivery or source valve to the gas-consuming equipment isolation valve. For other than undiluted liquefied petroleum gas (LP-Gas) systems, the point of delivery or source valve shall be the outlet of the service meter assembly or the outlet of the service regulator or service shutoff valve where no meter is provided. For undiluted LP-Gas, the point of delivery shall be considered to be the outlet of the final pressure regulator, exclusive of line gas regulators where no meter is installed. Where a meter is installed, the point of delivery shall be the outlet of the meter. For facilities that produce flammable gas for consumption on site, the point of delivery or source valve shall be the discharge isolation valve for the gas-producing equipment. Coverage of flammable gas piping systems other than fuel gas piping systems shall extend from the source valve serving the gas supply system to the gas-consuming equipment isolation valve.

Obtain an electronic copy from: [www.nfpa.org/56next](http://www.nfpa.org/56next)

Send comments (with copy to [psa@ansi.org](mailto:psa@ansi.org)) to: Same

## **NFPA (National Fire Protection Association)**

**The National Fire Protection Association announces the availability of NFPA 850 First Draft Report for concurrent review and comment by NFPA and ANSI.**

The First Draft Report contains the disposition of public inputs that were received for NFPA 850. The First Draft Reports for the NFPA 850 can be found on [www.nfpa.org/850next](http://www.nfpa.org/850next). All comments on NFPA 850 must be received by November 29, 2018. The disposition of all comments received from the review of the First Draft Report will be published in the Second Draft Report, and will also be available on the document's information page under the next edition tab. For more information on the rules and for up-to-date information on schedules and deadlines for processing NFPA Documents, check the NFPA website at <http://www.nfpa.org> or contact NFPA's Codes and Standards Administration, at NFPA, One Batterymarch Park, Quincy, MA, 02269-7471. Those who submit comments to NFPA's online submission system on NFPA 850 are invited to copy ANSI's Board of Standards Review.

### **Revision**

BSR/NFPA 850-201x, Recommended Practice for Fire Protection for Electric Generating Plants and High Voltage Direct Current Converter Stations (revision of ANSI/NFPA 850-2015)

This document provides recommendations for fire prevention and fire protection for electric generating plants and high-voltage direct-current converter stations, except as follows: Nuclear power plants are addressed in NFPA 805, Performance-Based Standard for Fire Protection for Light Water Reactor Electric Generating Plants; hydroelectric plants are addressed in NFPA 851, Recommended Practice for Fire Protection for Hydroelectric Generating Plants; and fuel cells are addressed in NFPA 853, Standard for the Installation of Stationary Fuel Cell Power Systems.

Obtain an electronic copy from: [www.nfpa.org/850next](http://www.nfpa.org/850next)

Send comments (with copy to [psa@ansi.org](mailto:psa@ansi.org)) to: Same

## **NFPA (National Fire Protection Association)**

### **New Standard**

BSR/NFPA 1700-201x, Guide for Structural Fire Fighting (new standard)

This guide addresses structural firefighting strategy, tactics, and tasks as supported by science-based research.

Obtain an electronic copy from: [www.nfpa.org/1700next](http://www.nfpa.org/1700next)

Send comments (with copy to [psa@ansi.org](mailto:psa@ansi.org)) to: Same

## NFPA (National Fire Protection Association)

### Revision

BSR/NFPA 61-201x, Standard for the Prevention of Fires and Dust Explosions in Agricultural and Food Processing Facilities (revision of ANSI/NFPA 61-2017)

This standard provides requirements applicable to agricultural and/or food processing facilities for managing or mitigating fire and explosion hazards of combustible agricultural or food processing dusts or related particulate solids.

Obtain an electronic copy from: [www.nfpa.org/61next](http://www.nfpa.org/61next)

Send comments (with copy to [psa@ansi.org](mailto:psa@ansi.org)) to: Same

BSR/NFPA 75-201x, Standard for the Fire Protection of Information Technology Equipment (revision of ANSI/NFPA 75-2017)

This standard covers the requirements for the protection of information technology equipment and information technology equipment areas.

Obtain an electronic copy from: [www.nfpa.org/75next](http://www.nfpa.org/75next)

Send comments (with copy to [psa@ansi.org](mailto:psa@ansi.org)) to: Same

BSR/NFPA 76-201x, Standard for the Fire Protection of Telecommunications Facilities (revision of ANSI/NFPA 76-2016)

Provides requirements for fire protection of telecommunications facilities where telecommunications services such as telephone (landline, wireless) transmission, data transmission, Internet transmission, voice-over Internet protocol (VoIP) transmission, and video transmission are rendered to the public. Telecommunications facilities include signal processing equipment areas, cable entrance facility areas, power areas, main distribution frame areas, standby engine areas, technical support areas, administrative areas, and building services and support areas occupied by a telecommunications service provider. It shall specifically exclude small outdoor structures that are normally unoccupied and that house telecommunications equipment, including on-grade, walk-in cabinets, on-grade huts, cell huts, and controlled environmental vaults.

Obtain an electronic copy from: [www.nfpa.org/76next](http://www.nfpa.org/76next)

Send comments (with copy to [psa@ansi.org](mailto:psa@ansi.org)) to: Same

BSR/NFPA 326-201x, Standard for the Safeguarding of Tanks and Containers for Entry, Cleaning, or Repair (revision of ANSI/NFPA 326-2015)

This standard shall apply to the safeguarding of tanks or containers operating at nominal atmospheric pressure that contain or have contained flammable or combustible liquids or other hazardous substances and related vapors or residues. This standard shall not apply to tank vehicles or tank cars; tanks, bunkers, or compartments on ships or barges or in a shipyard; gas plant equipment or gas distribution systems for natural or manufactured gas; or compressed or liquefied gas cylinders. This standard shall not apply to hot tapping. This standard shall not apply to the entry of a tank or container that contains an inert atmosphere.

Obtain an electronic copy from: [www.nfpa.org/326next](http://www.nfpa.org/326next)

Send comments (with copy to [psa@ansi.org](mailto:psa@ansi.org)) to: Same

BSR/NFPA 329-201x, Recommended Practice for Handling Releases of Flammable and Combustible Liquids and Gases (revision of ANSI/NFPA 329-2015)

This provides methods for responding to fire/explosion hazards resulting from the release of a flammable or combustible liquid, gas, or vapor that can migrate to a subsurface structure. The document is intended to address only fire/explosion hazards. Other authorities should be consulted regarding the environmental and health impacts and other hazardous conditions of such releases: Options for detecting and investigating the source of a release, for mitigating the fire/explosion hazards resulting from the release, and for tracing the release back to its source. The options outlined in this document are not intended to be, nor should they be considered to be, all inclusive or mandatory in any given situation. If better or more appropriate alternative methods are available, they should be used. The procedures outlined in this document can apply to hazardous substances other than flammable and combustible liquids that might have adverse human health effects. However, the physical characteristics of the specific hazardous substance released must be understood before any action is taken.

Obtain an electronic copy from: [www.nfpa.org/329next](http://www.nfpa.org/329next)

Send comments (with copy to [psa@ansi.org](mailto:psa@ansi.org)) to: Same

BSR/NFPA 601-201x, Standard for Security Services in Fire Loss Prevention (revision of ANSI/NFPA 601-2015)

This standard shall apply to the selection, requirements, duties, and training of security personnel who will perform fire loss prevention duties. It shall cover the following three categories of security services: (1) Protection of the property, including times when management is not present, (2) access and egress control into and within the confines of the protected property, and (3) carrying out procedures for the orderly conduct of various operations at the property.

Obtain an electronic copy from: [www.nfpa.org/601next](http://www.nfpa.org/601next)

Send comments (with copy to [psa@ansi.org](mailto:psa@ansi.org)) to: Same

BSR/NFPA 664-201x, Standard for the Prevention of Fires and Explosions in Wood Processing and Woodworking Facilities (revision of ANSI/NFPA 664-2017)

This standard shall establish the minimum requirements for fire and explosion prevention and protection of industrial, commercial, or institutional facilities that process wood or manufacture wood products, using wood or other cellulosic fiber as a substitute for or additive to wood fiber, and that process wood, creating wood chips, particles, or dust. Woodworking and wood processing facilities shall include, but are not limited to, wood flour plants, industrial woodworking plants, furniture plants, plywood plants, composite board plants, lumber mills, and production-type woodworking shops and carpentry shops that are incidental to facilities that would not otherwise fall within the purview of this standard. This standard shall apply to woodworking operations that occupy areas of more than 465 m<sup>2</sup> (5000 ft<sup>2</sup>) or where dust-producing equipment requires an aggregate dust collection flow rate of more than 2549 m<sup>3</sup>/hr (1500 ft<sup>3</sup>/min).

Obtain an electronic copy from: [www.nfpa.org/664next](http://www.nfpa.org/664next)

Send comments (with copy to [psa@ansi.org](mailto:psa@ansi.org)) to: Same

BSR/NFPA 730-201x, Guide for Premises Security (revision of ANSI/NFPA 730-2018)

This guide describes construction, protection, occupancy features, and practices intended to reduce security vulnerabilities to life and property. NFPA 730 is referred to in this standard as "this guide" or "the guide." This guide should not supersede government statutes or regulations.

Obtain an electronic copy from: [www.nfpa.org/730next](http://www.nfpa.org/730next)

Send comments (with copy to [psa@ansi.org](mailto:psa@ansi.org)) to: Same

BSR/NFPA 731-201x, Standard for the Installation of Electronic Premises Security Systems (revision of ANSI/NFPA 731-2017)

This standard covers the application, location, installation, performance, testing, and maintenance of electronic premises security systems and their components.

Obtain an electronic copy from: [www.nfpa.org/731next](http://www.nfpa.org/731next)

Send comments (with copy to [psa@ansi.org](mailto:psa@ansi.org)) to: Same

BSR/NFPA 804-201x, Standard for Fire Protection for Advanced Light Water Reactor Electric Generating Plants (revision of ANSI/NFPA 804-2015)

This standard applies only to advanced light-water-reactor electric generating plants and provides minimum fire-protection requirements to ensure safe shutdown of the reactor, minimize the release of radioactive materials to the environment, provide safety to life of on-site personnel, limit property damage, and protect continuity of plant operation. The fire protection is based on the principle of defense-in-depth. For plants that have adopted a risk-informed, performance-based approach to fire protection, subsequent changes to the fire protection program shall be made in accordance with NFPA 806, Performance-Based Standard for Fire Protection for Advanced Nuclear Reactor Electric Generating Plants Change Process.

Obtain an electronic copy from: [www.nfpa.org/804next](http://www.nfpa.org/804next)

Send comments (with copy to [psa@ansi.org](mailto:psa@ansi.org)) to: Same

BSR/NFPA 805-201x, Performance-Based Standard for Fire Protection for Light Water Reactor Electric Generating Plants (revision of ANSI/NFPA 805-2015)

This standard specifies the minimum fire-protection requirements for existing light-water nuclear power plants during all phases of plant operation, including shutdown, degraded conditions, and decommissioning.

Obtain an electronic copy from: [www.nfpa.org/805next](http://www.nfpa.org/805next)

Send comments (with copy to [psa@ansi.org](mailto:psa@ansi.org)) to: Same

BSR/NFPA 806-201x, Performance-Based Standard for Fire Protection for Advanced Nuclear Reactor Electric Generating Plants Change Process (revision of ANSI/NFPA 806-2015)

This standard provides minimum requirements for a risk-informed, performance-based change process for the fire-protection program for advanced nuclear-reactor electric-generating plants during construction and all phases of plant operation, including shutdown, degraded conditions, and decommissioning. Fundamental fire-protection elements for advanced nuclear-reactor electric-generating plants can be found in NFPA 804, Standard for Fire Protection for Advanced Light Water Reactor Electric Generating Plants.

Obtain an electronic copy from: [www.nfpa.org/806next](http://www.nfpa.org/806next)

Send comments (with copy to [psa@ansi.org](mailto:psa@ansi.org)) to: Same

BSR/NFPA 853-201x, Standard for the Installation of Stationary Fuel Cell Power Systems (revision of ANSI/NFPA 853-2015)

This standard shall apply to the design, construction, and installation of stationary fuel cell power systems. The scope of this document shall include the following: (1) A singular prepackaged, self-contained power system unit; (2) any combination of prepackaged, self-contained power system units; (3) power system units comprising two or more factory-matched modular components intended to be assembled in the field; and (4) Engineered and field-constructed power systems that employ fuel cells.

Obtain an electronic copy from: [www.nfpa.org/853next](http://www.nfpa.org/853next)

Send comments (with copy to [psa@ansi.org](mailto:psa@ansi.org)) to: Same

BSR/NFPA 950-201x, Standard for Data Development and Exchange for the Fire Service (revision of ANSI/NFPA 950-2015)

This standard is designed to standardize data for operable information sharing in support of the all-hazards response and to describe a digital information structure and associated requirements and workflows common to fire and emergency services delivery and management for emergency response and administrative use.

Obtain an electronic copy from: [www.nfpa.org/950next](http://www.nfpa.org/950next)

Send comments (with copy to [psa@ansi.org](mailto:psa@ansi.org)) to: Same

BSR/NFPA 1201-201x, Standard for Fire Officer Professional Qualifications (revision of ANSI/NFPA 1201-2015)

This standard identifies the minimum job performance requirements (JPRs) for a fire officer.

Obtain an electronic copy from: [www.nfpa.org/1021next](http://www.nfpa.org/1021next)

Send comments (with copy to [psa@ansi.org](mailto:psa@ansi.org)) to: Same

BSR/NFPA 1250-201x, Recommended Practice in Fire and Emergency Service Organization Risk Management (revision of ANSI/NFPA 1250-2015)

This recommended practice establishes minimum criteria to develop, implement, or evaluate a fire and emergency service organization (FESO) risk management program for effective risk identification, control, and financing.

Obtain an electronic copy from: [www.nfpa.org/1250next](http://www.nfpa.org/1250next)

Send comments (with copy to [psa@ansi.org](mailto:psa@ansi.org)) to: Same

BSR/NFPA 1616-201x, Standard on Mass Evacuation, Sheltering, and Re-entry Programs (revision of ANSI/NFPA 1616-2017)

This standard shall establish a common set of criteria for the process of organizing, planning, implementing, and evaluating a program for mass evacuation, sheltering, and re-entry. The requirements in this standard are based on the existence of a program for integrated disaster/emergency management and business continuity. An integrated program is defined in NFPA 1600. The integrated program is scalable to meet the needs of evacuation sheltering and re-entry.

Obtain an electronic copy from: [www.nfpa.org/1616next](http://www.nfpa.org/1616next)

Send comments (with copy to [psa@ansi.org](mailto:psa@ansi.org)) to: Same

BSR/NFPA 1620-201x, Standard for Pre-Incident Planning (revision of ANSI/NFPA 1620-2015)

This document provides criteria for developing pre-incident plans for use by personnel responding to emergencies. Not every portion of this standard is applicable to the development of all pre-incident plans. This document is not intended for pre-incident planning related to construction, alteration, and demolition. (See NFPA 241.) Annex A, Explanatory Material; Annex B, Case Histories; Annex C, Special or Unique Characteristics of Occupancy Classifications; and Annex D, Sample Pre-Incident Plan Field Collection Card and Facility Data Record forms provide information to the users of this document.

Obtain an electronic copy from: [www.nfpa.org/1620next](http://www.nfpa.org/1620next)

Send comments (with copy to [psa@ansi.org](mailto:psa@ansi.org)) to: Same

BSR/NFPA 1931-201x, Standard for Manufacturers Design of Fire Department Ground Ladders (revision of ANSI/NFPA 1931-2015)

This standard specifies the requirements for the design of fire-department ground ladders and for the design verification tests that are to be conducted by the ground ladder manufacturer. The tests specified in this standard are the responsibility of the ladder manufacturer only and are not to be performed by fire departments.

Obtain an electronic copy from: [www.nfpa.org/1931next](http://www.nfpa.org/1931next)

Send comments (with copy to [psa@ansi.org](mailto:psa@ansi.org)) to: Same

BSR/NFPA 1932-201x, Standard on Use, Maintenance, and Service Testing of In-Service Fire Department Ground Ladders (revision of ANSI/NFPA 1932-2015)

This standard specifies requirements for the use, maintenance, inspection, and service testing of fire-department ground ladders.

Obtain an electronic copy from: [www.nfpa.org/1932next](http://www.nfpa.org/1932next)

Send comments (with copy to [psa@ansi.org](mailto:psa@ansi.org)) to: Same

BSR/NFPA 2010-201x, Standard for Fixed Aerosol Fire-Extinguishing Systems (revision of ANSI/NFPA 2010-2015)

This standard contains the requirements for the design, installation, operation, testing, and maintenance of condensed and dispersed aerosol fire-extinguishing systems for total flooding applications. This standard also covers performance requirements and methods of testing for condensed aerosol systems, dispersed aerosol systems, and associated components.

Obtain an electronic copy from: [www.nfpa.org/2010next](http://www.nfpa.org/2010next)

Send comments (with copy to [psa@ansi.org](mailto:psa@ansi.org)) to: Same

## **NSF (NSF International)**

### ***Revision***

BSR/NSF 53-201x (i114r1), Drinking Water Treatment Units - Health Effects (revision of ANSI/NSF 53-2017)

It is the purpose of this Standard to establish minimum requirements for materials, design and construction, and performance of point-of-use and point-of-entry drinking-water treatment systems that are designed to reduce specific health-related contaminants in public or private water supplies. Such systems include point-of-entry drinking water treatment systems used to treat all or part of the water at the inlet to a residential facility or a bottled water production facility, and includes the material and components used in these systems. This Standard also specifies the minimum product literature and labeling information that a manufacturer shall supply to authorized representatives and system owners, as well as the minimum service-related obligations that the manufacturer shall extend to system owners.

Single copy price: Free

Obtain an electronic copy from: [https://standards.nsf.org/apps/group\\_public/download.php/44901/53i114r1-%20PFOA%20&%20PFOS%20Carbon%20-%20JC%20memo%20&%20ballot.pdf](https://standards.nsf.org/apps/group_public/download.php/44901/53i114r1-%20PFOA%20&%20PFOS%20Carbon%20-%20JC%20memo%20&%20ballot.pdf)

Send comments (with copy to [psa@ansi.org](mailto:psa@ansi.org)) to: [mleslie@nsf.org](mailto:mleslie@nsf.org)

BSR/NSF 58-201x (i83r1), Reverse Osmosis Drinking Water Treatment Systems (revision of ANSI/NSF 58-2017)

The purpose of this Standard is to establish minimum requirements for materials, design and construction, and performance of reverse-osmosis drinking-water treatment systems. This Standard also specifies the minimum product literature that manufacturers shall supply to authorized representatives and owners, as well as the minimum service-related obligations that manufacturers shall extend to system owners.

Single copy price: Free

Obtain an electronic copy from: [https://standards.nsf.org/apps/group\\_public/download.php/44977/58i83r1-%20PFOA%20&%20PFOS%20RO%20systems%20-%20JC%20memo%20&%20ballot.pdf](https://standards.nsf.org/apps/group_public/download.php/44977/58i83r1-%20PFOA%20&%20PFOS%20RO%20systems%20-%20JC%20memo%20&%20ballot.pdf)

Send comments (with copy to [psa@ansi.org](mailto:psa@ansi.org)) to: [mleslie@nsf.org](mailto:mleslie@nsf.org)

## **UL (Underwriters Laboratories, Inc.)**

### ***Reaffirmation***

BSR/UL 219-2013 (R201x), Standard for Lined Fire Hose for Interior Standpipes (reaffirmation of ANSI/UL 219-2013)

This proposal for UL 219 covers: (1) Reaffirmation and continuance of the 4th edition of the Standard for Lined Fire Hose for Interior Standpipes, UL 219, as an American National Standard.

Single copy price: Free

Obtain an electronic copy from: <http://www.shopulstandards.com>

Send comments (with copy to [psa@ansi.org](mailto:psa@ansi.org)) to: Wilbert Fletcher, (919) 954-9133, [Wilbert.fletcher@ul.com](mailto:Wilbert.fletcher@ul.com)

BSR/UL 60745-2-3-2013 (R201x), Standard for Safety for Standard for Hand-Held Motor-Operated Electric Tools - Safety - Part 2: Particular Requirements for Grinders, Polishers, and Disk-Type Sanders (reaffirmation of ANSI/UL 60745-2-3-2013)

This proposal for UL 60745-2-3 covers: (1) Reaffirmation and continuance of the second edition of the Standard for Hand-Held Motor-Operated Electric Tools - Safety - Part 2-3: Particular Requirements for Grinders, Polishers and Disk-Type Sanders, UL 60745-2-3, as an American National Standard.

Single copy price: Free

Obtain an electronic copy from: <http://www.shopulstandards.com>

Send comments (with copy to [psa@ansi.org](mailto:psa@ansi.org)) to: Elizabeth Northcott, (847) 664-3198, [Elizabeth.Northcott@ul.com](mailto:Elizabeth.Northcott@ul.com)

## Comment Deadline: December 4, 2018

Reaffirmations and withdrawals available electronically may be accessed at: [webstore.ansi.org](http://webstore.ansi.org)

### ASME (American Society of Mechanical Engineers)

#### *Reaffirmation*

BSR/ASME B1.20.1-2013 (R201x), Pipe Threads, General Purpose (Inch) (reaffirmation of ANSI/ASME B1.20.1-2013)

This Standard covers dimensions and gaging of pipe threads including NPT, NPSC, NPTR, NPSM, and NPSL.

Single copy price: \$60.00

Obtain an electronic copy from: <http://cstools.asme.org/publicreview>

For Reaffirmations and Withdrawn standards please view our catalog at <https://www.asme.org/shop/standards>

Send comments (with copy to [psa@ansi.org](mailto:psa@ansi.org)) to: Daniel Papert, (212) 591-7526, [papertd@asme.org](mailto:papertd@asme.org)

### ASME (American Society of Mechanical Engineers)

#### *Revision*

BSR/ASME PCC-1-201x, Guidelines for Pressure Boundary Bolted Flange Joint Assembly (revision of ANSI/ASME PCC-1-2013)

The bolted flange joint assembly (BFJA) guidelines described in this document may be used to develop effective joint assembly procedures for the broad range of sizes and service conditions normally encountered in industry. Guidance on troubleshooting BFJAs not providing leak-tight performance is also provided in this document.

Single copy price: Free

Obtain an electronic copy from: <http://cstools.asme.org/publicreview>

Order from: Mayra Santiago, ASME; [ansibox@asme.org](mailto:ansibox@asme.org)

Send comments (with copy to [psa@ansi.org](mailto:psa@ansi.org)) to: Steven Rossi, (212) 591-8460, [rossis@asme.org](mailto:rossis@asme.org)

### ITI (INCITS) (InterNational Committee for Information Technology Standards)

#### *New Standard*

INCITS 543-201x, Information technology - Fibre Channel - Physical Interfaces - 7 (FC-PI-7) (new standard)

The FC-PI-7 standard will define the requirements for new physical-layer variants that operate at higher data rates than those specified in FC-PI-6 and FC-PI-6P. The standard defines a single-lane serial variant and a four-lane parallel variant. It is desirable that new variants operate at similar distances as those of the corresponding variants specified in FC-PI-6 and FC-PI-6P.

Single copy price: Free

Obtain an electronic copy from: <https://standards.incits.org/apps/org/workgroup/eb/download.php/101842>

Order from: <https://standards.incits.org/apps/org/workgroup/eb/download.php/101842>

Send comments (with copy to [psa@ansi.org](mailto:psa@ansi.org)) to: [comments@standards.incits.org](mailto:comments@standards.incits.org)

## Notice of Withdrawn ANS by an ANSI-Accredited Standards Developer

In accordance with clause 4.2.1.3.2 Withdrawal by ANSI-Accredited Standards Developer of the ANSI Essential Requirements, the following American National Standards have been withdrawn as an ANS.

### NFPA (National Fire Protection Association)

ANSI/NFPA 1965-2014, Standard for Fire Hose Appliances

Questions may be directed to: Dawn Michele Bellis, (617) 984-7246, [dbellis@nfpa.org](mailto:dbellis@nfpa.org)



# Call for Members (ANS Consensus Bodies)

Directly and materially affected parties who are interested in participating as a member of an ANS consensus body for the standards listed below are requested to contact the sponsoring standards developer directly and in a timely manner.

## **ASHRAE (American Society of Heating, Refrigerating and Air-Conditioning Engineers, Inc.)**

**Office:** 1791 Tullie Circle NE  
Atlanta, GA 30329

**Contact:** *Tanisha Meyers-Lisle*

**Phone:** (678) 539-1111

**E-mail:** [tmlisle@ashrae.org](mailto:tmlisle@ashrae.org)

BSR/ASHRAE Standard 40-201X, Methods of Testing for Rating Heat-Operated Unitary Air-Conditioning and Heat-Pump Equipment (revision of ANSI/ASHRAE Standard 40-2014)

BSR/ASHRAE Standard 110-201X, Methods of Testing Performance of Laboratory Fume Hoods (revision of ANSI/ASHRAE Standard 110-2016)

## **ASSP (ASC A10) (American Society of Safety Professionals)**

**Office:** 520 N. Northwest Highway  
Park Ridge, IL 60068

**Contact:** *Tim Fisher*

**Phone:** (847) 768-3411

**E-mail:** [TFisher@ASSP.org](mailto:TFisher@ASSP.org)

BSR/ASSE A10.46-201x, Hearing Loss Prevention for Construction and Demolition Workers (revision and redesignation of ANSI/ASSP A10.46-201x)

## **ASSP (Safety) (American Society of Safety Professionals)**

**Office:** 520 N. Northwest Highway  
Park Ridge, IL 60068

**Contact:** *Tim Fisher*

**Phone:** (847) 768-3411

**E-mail:** [TFisher@ASSP.org](mailto:TFisher@ASSP.org)

BSR/ASSP Z10.1-201X, Occupational Health and Safety Management Systems (revision and redesignation of ANSI/ASSE Z10.1-201X)

## **ECIA (Electronic Components Industry Association)**

**Office:** 2214 Rock Hill Road  
Suite 265  
Herndon, VA 20170-4212

**Contact:** *Laura Donohoe*

**Phone:** (571) 323-0294

**E-mail:** [ldonohoe@ecianow.org](mailto:ldonohoe@ecianow.org)

BSR/EIA 364-119-201x, Removal Tool Rotation Test Procedure for Electrical Connectors (new standard)

## **ITI (INCITS) (InterNational Committee for Information Technology Standards)**

**Office:** 1101 K Street NW  
Suite 610  
Washington, DC 20005

**Contact:** *Rachel Porter*

**Phone:** (202) 737-8888

**E-mail:** [comments@standards.incits.org](mailto:comments@standards.incits.org)

INCITS 543-201x, Information technology - Fibre Channel - Physical Interfaces - 7 (FC-PI-7) (new standard)

## **NEMA (ASC C78) (National Electrical Manufacturers Association)**

**Office:** 1300 N 17th St  
Rosslyn, VA 22209

**Contact:** *Michael Erbesfeld*

**Phone:** 703-841-3262

**E-mail:** [Michael.Erbesfeld@nema.org](mailto:Michael.Erbesfeld@nema.org)

BSR C78.54-201X, Standard for Electric Lamps - Specification Sheet for Tubular Fluorescent Replacement and Retrofit LED Lamps (new standard)

## **NSF (NSF International)**

**Office:** 789 N. Dixboro Road  
Ann Arbor, MI 48105-9723

**Contact:** *Monica Leslie*

**Phone:** (734) 827-5643

**E-mail:** [mleslie@nsf.org](mailto:mleslie@nsf.org)

BSR/NSF 53-201x (i114r1), Drinking Water Treatment Units - Health Effects (revision of ANSI/NSF 53-2017)

BSR/NSF 58-201x (i83r1), Reverse Osmosis Drinking Water Treatment Systems (revision of ANSI/NSF 58-2017)

BSR/NSF 455-2-201x (i1r3), Good Manufacturing Practices for Dietary Supplements (new standard)

### **NSF International Designations**

In the September 5, 2014 Standards Action, NSF International announced a new family of standards for a program called the Global Retailers and Manufacturers Alliance (GRMA). Since then, BSR/NSF 455-3-201x has been withdrawn from consideration and the designation and title of these PINS have been reassigned. The re-designation of these proposed ANS are as follows:

BSR/NSF 455-1-201x, Glossary of GRMA terminology (PINS to be filed shortly)

BSR/NSF 455-2-201x, Good Manufacturing Practices for Dietary Supplements

BSR/NSF 455-3-201x, Good Manufacturing Practices for Cosmetics

BSR/NSF 455-4-201x, Good Manufacturing Practices for Over the Counter Drugs

**OIX (Open-IX Association)**

**Office:** 750 Third Avenue  
9th Floor  
New York, NY 10017

**Contact:** *Richard Wolfram*

**Phone:** (917) 225-3950

**E-mail:** [rwolfram@rwolframlex.com](mailto:rwolfram@rwolframlex.com)

BSR/OIX 1-201x, IXP Technical Standard (new standard)

BSR/OIX 2-201x, Data Center Technical Standard (new standard)

# **Call for Members (ANS Consensus Bodies)**

## **Call for Committee Members**

### **ASC O1 – Safety Requirements for Woodworking Machinery**

Are you interested in contributing to the development and maintenance of valuable industry safety standards? The ASC O1 is currently looking for members in the following categories:

- General Interest
- Government
- Producer
- User

If you are interested in joining the ASC O1, contact WMMA Associate Director Jennifer Miller at [jennifer@wmma.org](mailto:jennifer@wmma.org).

# Final Actions on American National Standards

The standards actions listed below have been approved by the ANSI Board of Standards Review (BSR) or by an ANSI-Audited Designator, as applicable.

## **ASME (American Society of Mechanical Engineers)**

### **Revision**

ANSI/ASME B16.9-2018, Factory-Made Wrought Butt Welding Fittings (revision of ANSI/ASME B16.9-2012): 9/25/2018

## **ASSP (ASC A10) (American Society of Safety Professionals)**

### **Reaffirmation**

ANSI/ASSP A10.40-2007 (R2018), Reduction of Musculoskeletal Problems in Construction (reaffirmation and redesignation of ANSI/ASSE A10.40-2007 (R2013)): 9/27/2018

## **CSA (CSA Group)**

### **Reaffirmation**

ANSI/CSA CHMC 1-2014 (R2018), Test Methods for Evaluating Material Compatibility In Compressed Hydrogen Applications - Metals (reaffirmation of ANSI/CSA CHMC 1-2014): 9/27/2018

## **ESTA (Entertainment Services and Technology Association)**

### **Revision**

ANSI/E1.1-2018, Entertainment Technology Construction and Use of Wire Rope Ladders (revision of ANSI E1.1-2012): 9/27/2018

## **IEEE (Institute of Electrical and Electronics Engineers)**

### **Revision**

ANSI/IEEE 802.21-2017, Standard for Local and Metropolitan Area Networks - Part 21: Media Independent Services Framework (revision of ANSI/IEEE 802.21-2009): 9/27/2018

## **NSF (NSF International)**

### **Revision**

ANSI/NSF 49-2018 (i77r3), Biosafety Cabinetry - Design, Construction, Performance, and Field Certification (revision of ANSI/NSF 49-2016): 9/25/2018

## **PEARL (Professional Electrical Apparatus Recyclers League)**

### **New Standard**

ANSI/PEARL EERS-2017, Professional Electrical Apparatus Reconditioning League Electrical Equipment Reconditioning Standard for Electrical Apparatus and Equipment Used in Commercial and Industrial Applications (new standard): 9/25/2018

## **UL (Underwriters Laboratories, Inc.)**

### **New National Adoption**

ANSI/UL 60079-29-4-2018, Standard for Safety for Explosive Atmospheres - Part 29-4: Gas Detectors - Performance Requirements of Open Path Detectors for Flammable Gases (national adoption of IEC 60079-29-4 with modifications and revision of ANSI/ISA 12.13.04/FM 6325-2007 (R2014)): 8/24/2018

ANSI/UL 60079-29-4-2018a, Standard for Safety for Explosive Atmospheres - Part 29-4: Gas Detectors - Performance Requirements of Open Path Detectors for Flammable Gases (national adoption with modifications of IEC 60079-29-4): 8/24/2018

ANSI/UL 62841-2-17-2018, Standard for Safety for Electric Motor-Operated Hand-Held Tools, Transportable Tools and Lawn and Garden Machinery - Safety - Part 2-17 Particular Requirements for Hand-Held Routers (identical national adoption of IEC 62841-2-17): 9/7/2018

## **VC (ASC Z80) (The Vision Council)**

### **Revision**

ANSI Z80.10-2018, Tonometers (revision of ANSI Z80.10-2014): 9/27/2018

## **VITA (VMEbus International Trade Association (VITA))**

### **Reaffirmation**

ANSI/VITA 66.3-2012 (R2018), Optical Interconnect on VPX - Mini Expanded Beam Variant (reaffirmation of ANSI/VITA 66.3-2012): 9/28/2018

# Project Initiation Notification System (PINS)

ANSI Procedures require notification of ANSI by ANSI-accredited standards developers (ASD) of the initiation and scope of activities expected to result in new or revised American National Standards (ANS). Early notification of activity intended to reaffirm or withdraw an ANS and in some instances a PINS related to a national adoption is optional. The mechanism by which such notification is given is referred to as the PINS process. For additional information, see clause 2.4 of the ANSI Essential Requirements: Due Process Requirements for American National Standards.

Following is a list of proposed actions and new ANS that have been received recently from ASDs. Please also review the section in Standards Action entitled "American National Standards Maintained Under Continuous Maintenance" for additional or comparable information with regard to standards maintained under the continuous maintenance option. Use the following Public Document Library url to access PDF & EXCEL reports of approved & proposed ANS: [List of Approved and Proposed ANS](#)

Directly and materially affected interests wishing to receive more information or to submit comments are requested to contact the standards developer directly within 30 days of the publication of this announcement.

## **AAFS (American Academy of Forensic Sciences)**

Contact: Teresa Ambrosius, (719) 453-1036, [tambrosius@aafs.org](mailto:tambrosius@aafs.org)  
410 North 21st Street, Colorado Springs, CO 80904

### **New Standard**

BSR/ASB BPR 060-201x, Guidelines for Barrel and Overall Length Measurements for Firearms (new standard)

Stakeholders: Firearm and tool mark examiners and technicians; forensic service providers that provide firearm and tool mark examination services; judicial system; law enforcement investigators, and general public.

Project Need: Minimum length standards for barrel and overall length (BL-OL) of certain firearms may be mandated by law, which necessitates the reporting on BL-OL measurements. Many forensic accreditation standards require measurement traceability, often along with estimating measurement uncertainty. This document will provide guidelines for measurement traceability and estimating uncertainty of measurement.

This document provides the guidelines for measuring barrel length and overall length (BL-OL) of firearms, including guidelines for measurement traceability and estimating uncertainty of BL-OL measurements in reports.

## **ASC X9 (Accredited Standards Committee X9, Incorporated)**

Contact: Ambria Frazier, (410) 267-7707, [Ambria.frazier@x9.org](mailto:Ambria.frazier@x9.org)  
275 West Street, Suite 107, Annapolis, MD 21401

### **New Standard**

BSR X9.132-201x, Issuer PIN Generation, Verification and Storage Methodologies Using AES (new standard)

Stakeholders: Debit and credit card issuers and processors.

Project Need: More than 85% of PIN generation, storage, and verification processes in the world are based off a DES-based algorithm or are using other methodologies that create risks for the cardholder, issuer, and processor. While standards have eliminated DES as an approved algorithm, most issuers are still using single DES in their processing to generate, store, and verify PINs. There is currently no published industry standard for PIN encryption for storage. This new standard will provide a consistent methodology across the industry, creating a stable and more secure environment for everyone.

Card-issuing back-end host applications need to convert existing DES-based PIN protection and verification methodologies to an AES-based environment. Methodologies need to provide secure mechanisms for issuers to store customer PINs in multiple locations such that applications that verify PINs cannot recover customers' clear PINs, but that applications that manage customers' cards and PINs have the ability to recover customer PINs.

**BSR X9.144-201x, Production Subpoena Orders Exchange (new standard)**

Stakeholders: Most financial institutions and agencies in the U.S. are stakeholders processing subpoena orders.

Project Need: There is a growing volume of requests due to overall increases in regulatory and legal environment. Standards in this area will bring about the following benefits: (1) Reduced errors; (2) Improved quality of the process and resulting outputs; (3) Improved tracking and management of service levels; (4) Reduced operational costs (after initial investment; business case TBD); (5) Improved records management; and (6) Improved fulfillment time – quicker results to the requester (images provided and fees collected).

In today's environment, subpoenas are served in multiple formats by federal, state, and local government agencies and law firms. These documents are served via mail, email, fax, or physically served to the bank. When the bank receives the orders the process for responding and fulfilling the order is highly manual, time consuming, and prone to errors, and there are limited areas where automation is applied. In most cases, the basic types of information required for processing are the same across the different request types. By creating a set of standards for electronic file formats for the different request types, benefits will be realized by both the subpoena requester and responder through automation.

**ASHRAE (American Society of Heating, Refrigerating and Air-Conditioning Engineers, Inc.)**

Contact: *Tanisha Meyers-Lisle, (678) 539-1111, tmlisle@ashrae.org*  
1791 Tullie Circle NE, Atlanta, GA 30329

**Revision**

BSR/ASHRAE Standard 40-201X, Methods of Testing for Rating Heat Operated Unitary Air-Conditioning and Heat-Pump Equipment (revision of ANSI/ASHRAE Standard 40-2014)

Stakeholders: Equipment manufacturers of products impacted by this standard, test labs, gas utilities, government agencies such as DOE.

Project Need: The existing standard needs to be updated to include gas-engine drive heat pumps, which are now commercially available.

This standard applies to heat-operated unitary air conditioners and heat pumps consisting of one or more assemblies, including engine-driven systems. Where such equipment is provided in more than one assembly, the separate assemblies are designed to be used together.

BSR/ASHRAE Standard 110-201X, Methods of Testing Performance of Laboratory Fume Hoods (revision of ANSI/ASHRAE Standard 110-2016)

Stakeholders: Laboratory buildings for universities, private companies, and even public school systems to be able to test their fume hoods more efficiently and effectively.

Project Need: The current standard is based on a tracer gas (SF6) that has been outlawed by many states in the U.S. and countries around the world. Research Project RP-1573 is nearing completion that has a goal to determine a replacement gas and method of test to inject and analyze the new gas to check the capture performance of the fume hoods. Hoods are recommended commissioned prior to use to verify containment performance. In addition, fume hoods are required to be tested on an annual basis to proper operation. Their complexity and cost of the current methods appear to be impact the utilization of the test for these purposes, potentially affecting proper operation and protection of the personnel.

The purpose of this standard is to specify a quantitative and qualitative test method for evaluating fume containment of laboratory fume hoods.

**BICSI (Building Industry Consulting Service International)**

Contact: *Jeff Silveira, (813) 903-4712, jsilveira@bicsi.org*  
8610 Hidden River Parkway, Tampa, FL 33637

**New Standard**

BSR/BICSI N3-201x, Planning and Installation Methods for the Bonding and Grounding of Telecommunication and ICT Systems and Infrastructure (new standard)

Stakeholders: Telecom, ICT and converged system infrastructure designers and installers, manufacturers of building and communication systems, products and requisite infrastructure that utilizing network communications, system integrators, professionals and inspectors for building systems that utilize network connectivity.

Project Need: As ICT system become more prevalent through the global adoption of IoT, smart buildings, and other network-enabled systems, effective bonding and grounding systems provide for these systems to exist without additional risk of harm to people, property, or systems for induced, stray or accidental currents. Whereas many codes and standards address the design of these systems, proper installation guidance is often left to manufacturer's instructions.

This standard specifies aspects of planning and installation of bonding and grounding systems for telecommunications and ICT systems and infrastructure within a customer premises. Proper planning and installation provides for effective and optimal system performance of the bonding and grounding system, allowing the system to meet its objective in preventing damage to people or assets.

## OIX (Open-IX Association)

Contact: Richard Wolfram, (917) 225-3950, [rwolfram@rwolframlex.com](mailto:rwolfram@rwolframlex.com)  
750 Third Avenue, 9th Floor, New York, NY 10017

### **New Standard**

BSR/OIX 1-201x, IXP Technical Standard (new standard)

Stakeholders: Data center providers, network providers, IX providers, any enterprise customer placing equipment in a data center or connecting to an internet exchange, Cloud providers, content providers, content distribution networks, universities, cable companies, Internet of Things companies and users.

Project Need: Open-IX has developed the IXP standard to help overcome inconsistencies in connectivity, resiliency, and security in the Internet, by promoting uniform specifications for data transfer and physical connectivity and reliability.

The IXP standard ("OIX-1" or "IXP Standard") defines the technical requirements for an Internet Exchange Point to be certified. An IXP is a physical network infrastructure operated by a single entity in order to facilitate the exchange of Internet traffic between Autonomous Systems (ASs). The intention is to connect more than two ASs, and there must be a clear and open policy for others to join. The standard sets forth requirements, notably, for the minimal service offering, infrastructure, and operations. These categories include, in particular, requirements for a public exchange VLAN (IX), permitting any-to-any interconnection; IEEE 802.3 Ethernet connectivity physical interface; traffic forwarding via specified Ethertypes; customer interface; infrastructure requirements for the IXP switching platform, the IP address space and any route server provided by the IXP; and operational requirements such as contact information for technical support, monitoring of the exchange platform and publication of statistics regarding traffic, participants on the peering platform and relevant AS numbers.

BSR/OIX 2-201x, Data Center Technical Standard (new standard)

Stakeholders: Data center providers, network providers, IX providers, any enterprise customer placing equipment in a data center or connecting to an internet exchange, Cloud providers, content providers, content distribution networks, universities, cable companies, Internet of Things companies and users.

Project Need: Open-IX has developed the IXP standard to help overcome inconsistencies in connectivity, resiliency, and security in the Internet, by promoting uniform specifications for data transfer and physical connectivity and reliability.

The Open-IX Data Center Technical Standard ("OIX-2" or "DC Standard") establishes criteria for Data Centers to support an IXP. (An IXP, or Internet Exchange Point, is a physical network infrastructure operated by a single entity to facilitate the exchange of Internet traffic between Autonomous Systems.) The DC Standard consists of both physical and operational requirements. Among the physical requirements, the DC Standard sets forth, notably, the minimum level of resiliency and redundancy with respect to utility feeds, transformers, UPS, electrical distribution infrastructure, back-up generators and cooling capacity, all of which must be no less than N+1, where N is the number of network-infrastructure elements required to support active customers (i.e., PDUs, UPSs, generators, chillers, etc.); a minimum standard for network access into the data center and the establishment of a Meet-Me- Room with an established process and pricing for cross-connects to other data center customers and IXPs; criteria for fire protection, water sources, building security and building management; and parameters for locations of the data centers with respect to likely weather or geologic events as well as likely rail or plane transportation incidents. On the operational side, the DC Standard sets forth requirements for general rules governing facility use; local, state and federal licensing; power and cooling system commissioning; maintenance; operating procedures, including emergency response; hours of operation; change management; workflow management; disaster plans; customer communications; general compliance procedures; environmental compliance; and energy conservation. For some of the requirements there is an exception standard that the data center may meet, particularly with respect to existing facilities, but failure to meet the standard requirement or the exception for each category requires non-certification.

## SAAMI (Sporting Arms and Ammunition Manufacturers Institute)

Contact: Randy Bimson, (220) 342-6435, [rbimson@saami.org](mailto:rbimson@saami.org)  
11 Mile High Road, Newtown, CT 06470-2359

### **New Standard**

BSR/SAAMI Z299.7-201x, Standard Voluntary Industry Performance Standards for Equipment and Procedures Related to the Measurement of Firearm Dimensions and Other Characteristics for the Use of Commercial Manufacturers (new standard)

Stakeholders: Commercial manufacturers, test labs, non-commercial end users, government agencies.

Project Need: Provide a single-point reference standard for commercial manufacturers of sporting firearms.

In the interests of uniformity, safety, and interchangeability, this Standard provides consolidation and compilation of the measurement systems, processes, and protocols commonly referenced and used by commercial manufacturers to assess the functional properties and performance of firearms.

BSR/SAAMI Z299.8-201x, Standard Voluntary Industry Performance Standards for Equipment and Procedures Related to the Measurement of Ammunition Dimensions and Other Characteristics for the Use of Commercial Manufacturers (new standard)

Stakeholders: Commercial manufacturers, test labs, non-commercial end users, government agencies.

Project Need: Provide a single-point reference standard for commercial manufacturers of sporting ammunition.

In the interests of uniformity, safety, and interchangeability, this Standard provides consolidation and compilation of the measurement systems, processes, and protocols commonly referenced and used by commercial manufacturers to assess the functional and performance properties of ammunition.

BSR/SAAMI Z299.9-201x, Standard Voluntary Industry Performance Standards for Pressure Measurement and Proof Testing of Muzzle-Loading Firearms for the Use of Commercial Manufacturers (new standard)

Stakeholders: Commercial manufacturers, test labs, end users.

Project Need: Provide standards for commercial manufacturers of muzzle-loading firearms.

In the interests of function, safety, and interchangeability, this Standard provides recommended bounding values, processes, procedures, and equipment for pressure measurement (service and proof) and dimensional criteria for use by commercial manufacturers.

### **TMA (The Monitoring Association)**

Contact: Bryan Ginn, (703) 242-4670 xt 19, bginn@tma.us  
8150 Leesburg Pike, Suite 700, Vienna, VA 22182

#### **Revision**

BSR/TMA CS-V-01-201x, Alarm Confirmation, Verification and Notification Procedures (revision and redesignation of ANSI/CSAA CS-V-01-2016)

Stakeholders: Alarm monitoring facilities.

Project Need: Additional section needed for Mobile Device Alarm Verification.

This standard defines methods by which false dispatches can be greatly reduced. It has been proven that confirming and verifying an alarm signal by a monitoring central station will drastically reduce false dispatches. This standard takes confirmation to its next level by defining multiple attempt confirmation, biometric, audio, and video confirmation.



# American National Standards Maintained Under Continuous Maintenance

The ANSI Essential Requirements: Due Process Requirements for American National Standards provides two options for the maintenance of American National Standards (ANS): periodic maintenance (see clause 4.7.1) and continuous maintenance (see clause 4.7.2). Continuous maintenance is defined as follows:

The standard shall be maintained by an accredited standards developer. A documented program for periodic publication of revisions shall be established by the standards developer. Processing of these revisions shall be in accordance with these procedures. The published standard shall include a clear statement of the intent to consider requests for change and information on the submittal of such requests. Procedures shall be established for timely, documented consensus action on each request for change and no portion of the standard shall be excluded from the revision process. In the event that no revisions are issued for a period of four years, action to reaffirm or withdraw the standard shall be taken in accordance with the procedures contained in the ANSI Essential Requirements.

The Executive Standards Council (ExSC) has determined that for standards maintained under the Continuous Maintenance option, separate PINS announcements are not required. The following ANSI Accredited Standards Developers have formally registered standards under the Continuous Maintenance option

- **AAMI (Association for the Advancement of Medical Instrumentation)**
- **AARST (American Association of Radon Scientists and Technologists)**
- **AGA (American Gas Association)**
- **AGSC-AGRSS (Auto Glass Safety Council)**
- **ASC X9 (Accredited Standards Committee X9, Incorporated)**
- **ASHRAE (American Society of Heating, Refrigerating and Air-Conditioning Engineers, Inc.)**
- **ASME (American Society of Mechanical Engineers)**
- **ASTM (ASTM International)**
- **GBI (Green Building Initiative)**
- **HL7 (Health Level Seven)**
- **IES (Illuminating Engineering Society)**
- **ITI (InterNational Committee for Information Technology Standards)**
- **MHI (Material Handling Industry)**
- **NAHBRC (NAHB Research Center, Inc.)**
- **NBBPVI (National Board of Boiler and Pressure Vessel Inspectors)**
- **NCPDP (National Council for Prescription Drug Programs)**
- **NEMA (National Electrical Manufacturers Association)**
- **NISO (National Information Standards Organization)**
- **NSF (NSF International)**
- **PRCA (Professional Ropes Course Association)**
- **RESNET (Residential Energy Services Network, Inc.)**
- **SAE (SAE International)**
- **TCNA (Tile Council of North America)**
- **TIA (Telecommunications Industry Association)**
- **UL (Underwriters Laboratories, Inc.)**

To obtain additional information with regard to these standards, including contact information at the ANSI Accredited Standards Developer, please visit ANSI Online at [www.ansi.org/asd](http://www.ansi.org/asd), select "Standards Activities," click on "Public Review and Comment" and "American National Standards Maintained Under Continuous Maintenance." This information is also available directly at [www.ansi.org/publicreview](http://www.ansi.org/publicreview)

Alternatively, you may contact the Procedures & Standards Administration department (PSA) at [psa@ansi.org](mailto:psa@ansi.org) or via fax at 212-840-2298. If you request that information be provided via E-mail, please include your E-mail address; if you request that information be provided via fax, please include your fax number. Thank you.

# ANSI-Accredited Standards Developers Contact Information

The addresses listed in this section are to be used in conjunction with standards listed in PINS, Call for Comment and Final Actions. This section is a list of developers who have submitted standards for this issue of *Standards Action* – it is not intended to be a list of all ANSI-Accredited Standards Developers. Please send all address corrections to Standards Action Editor at [standact@ansi.org](mailto:standact@ansi.org).

<p><b>AAFS</b> American Academy of Forensic Sciences 410 North 21st Street Colorado Springs, CO 80904 Phone: (719) 453-1036 Web: <a href="http://www.aafs.org">www.aafs.org</a></p>	<p><b>ASTM</b> ASTM International 100 Barr Harbor Drive West Conshohocken, PA 19428-2959 Phone: (610) 832-9744 Web: <a href="http://www.astm.org">www.astm.org</a></p>	<p><b>IIAR</b> International Institute of Ammonia Refrigeration 1001 N. Fairfax Street Suite 503 Alexandria, VA 22314-1797 Phone: (703) 312-4200 Web: <a href="http://www.iiar.org">www.iiar.org</a></p>	<p><b>PEARL</b> Professional Electrical Apparatus Recyclers League 10200 W. 44th St, Ste. 304 Wheat Ridge, CO 80033 Phone: (720) 881-6117 Web: <a href="http://www.pearl1.org">www.pearl1.org</a></p>
<p><b>AHRI</b> Air-Conditioning, Heating, and Refrigeration Institute 2121 Wilson Blvd Suite 500 Arlington, VA 22201 Phone: (703) 600-0327 Web: <a href="http://www.ahrinet.org">www.ahrinet.org</a></p>	<p><b>AWS</b> American Welding Society 8669 Doral Blvd Suite 130 Doral, FL 33166 Phone: (800) 443-9353 xt306 Web: <a href="http://www.aws.org">www.aws.org</a></p>	<p><b>ITI (INCITS)</b> InterNational Committee for Information Technology Standards 1101 K Street NW Suite 610 Washington, DC 20005 Phone: (202) 737-8888 Web: <a href="http://www.incits.org">www.incits.org</a></p>	<p><b>PMMI (Organization)</b> PMMI - The Association for Packaging and Processing Technologies 11911 Freedom Drive Suite 600 Reston, VA 20190 Phone: (269) 781-6567 Web: <a href="http://www.pmmi.org">www.pmmi.org</a></p>
<p><b>ASABE</b> American Society of Agricultural and Biological Engineers 2950 Niles Road Saint Joseph, MI 49085 Phone: (269) 932-7027 Web: <a href="http://www.asabe.org">www.asabe.org</a></p>	<p><b>BICSI</b> Building Industry Consulting Service International 8610 Hidden River Parkway Tampa, FL 33637 Phone: (813) 903-4712 Web: <a href="http://www.bicsi.org">www.bicsi.org</a></p>	<p><b>NCPDP</b> National Council for Prescription Drug Programs 9240 East Raintree Drive Scottsdale, AZ 85260 Phone: (480) 296-4584 Web: <a href="http://www.ncdpd.org">www.ncdpd.org</a></p>	<p><b>SAAMI</b> Sporting Arms and Ammunition Manufacturers Institute 11 Mile High Road Newtown, CT 06470-2359 Phone: (220) 342-6435 Web: <a href="http://www.saami.org">www.saami.org</a></p>
<p><b>ASC X9</b> Accredited Standards Committee X9, Incorporated 275 West Street Suite 107 Annapolis, MD 21401 Phone: (410) 267-7707 Web: <a href="http://www.x9.org">www.x9.org</a></p>	<p><b>CSA</b> CSA Group 8501 E. Pleasant Valley Road Cleveland, OH 44131 Phone: (216) 524-4990 Web: <a href="http://www.csagroup.org">www.csagroup.org</a></p>	<p><b>NEMA (ASC C78)</b> National Electrical Manufacturers Association 1300 N 17th St Rosslyn, VA 22209 Phone: 703-841-3262 Web: <a href="http://www.nema.org">www.nema.org</a></p>	<p><b>TMA</b> The Monitoring Association 8150 Leesburg Pike, Suite 700 Vienna, VA 22182 Phone: (703) 242-4670 xt 19 Web: <a href="http://www.csaaul.org">www.csaaul.org</a></p>
<p><b>ASHRAE</b> American Society of Heating, Refrigerating and Air-Conditioning Engineers, Inc. 1791 Tullie Circle NE Atlanta, GA 30329 Phone: (678) 539-1111 Web: <a href="http://www.ashrae.org">www.ashrae.org</a></p>	<p><b>ECIA</b> Electronic Components Industry Association 2214 Rock Hill Road Suite 265 Herndon, VA 20170-4212 Phone: (571) 323-0294 Web: <a href="http://www.ecianow.org">www.ecianow.org</a></p>	<p><b>NEMA (ASC ESS)</b> National Electrical Manufacturers Association 1300 N 17th St Rosslyn, VA 22209 Phone: (703) 841-3279 Web: <a href="http://www.nema.org">www.nema.org</a></p>	<p><b>UL</b> Underwriters Laboratories, Inc. 12 Laboratory Drive Research Triangle Park, NC 27709 Phone: (919) 954-9133 Web: <a href="http://www.ul.com">www.ul.com</a></p>
<p><b>ASME</b> American Society of Mechanical Engineers Two Park Avenue New York, NY 10016-5990 Phone: (212) 591-8521 Web: <a href="http://www.asme.org">www.asme.org</a></p>	<p><b>ESTA</b> Entertainment Services and Technology Association 630 Ninth Avenue Suite 609 New York, NY 10036-3748 Phone: (212) 244-1505 Web: <a href="http://www.esta.org">www.esta.org</a></p>	<p><b>NFPA</b> National Fire Protection Association One Batterymarch Park Quincy, MA 02169 Phone: (617) 984-7246 Web: <a href="http://www.nfpa.org">www.nfpa.org</a></p>	<p><b>VC (ASC Z80)</b> The Vision Council 225 Reinekers Lane Alexandria, VA 22314 Phone: 585-387-9913 Web: <a href="http://www.z80asc.com">www.z80asc.com</a></p>
<p><b>ASSP (Safety)</b> American Society of Safety Professionals 520 N. Northwest Highway Park Ridge, IL 60068 Phone: (847) 768-3411 Web: <a href="http://www.assp.org">www.assp.org</a></p>	<p><b>IAPMO (ASSE Chapter)</b> ASSE International Chapter of IAPMO 18927 Hickory Creek Drive Suite 220 Mokena, IL 60448 Phone: (708) 995-3015 Web: <a href="http://www.asse-plumbing.org">www.asse-plumbing.org</a></p>	<p><b>NSF</b> NSF International 789 N. Dixboro Road Ann Arbor, MI 48105-9723 Phone: (734) 827-6866 Web: <a href="http://www.nsf.org">www.nsf.org</a></p>	<p><b>VITA</b> VMEbus International Trade Association (VITA) 929 W. Portobello Avenue Mesa, AZ 85210 Phone: (602) 281-4497 Web: <a href="http://www.vita.com">www.vita.com</a></p>
	<p><b>IEEE</b> Institute of Electrical and Electronics Engineers 445 Hoes Lane Piscataway, NJ 08854 Phone: (732) 562-3854 Web: <a href="http://www.ieee.org">www.ieee.org</a></p>	<p><b>OIX</b> Open-IX Association 750 Third Avenue 9th Floor New York, NY 10017 Phone: (917) 225-3950 Web: <a href="http://www.open-ix.org">www.open-ix.org</a></p>	



# ISO & IEC Draft International Standards

This section lists proposed standards that the International Organization for Standardization (ISO) and the International Electrotechnical Commission (IEC) are considering for approval. The proposals have received substantial support within the technical committees or subcommittees that developed them and are now being circulated to ISO and IEC members for comment and vote. Standards Action readers interested in reviewing and commenting on these documents should order copies from ANSI.

## Comments

Comments regarding ISO documents should be sent to ANSI's ISO Team (isot@ansi.org); comments on ISO documents must be submitted electronically in the approved ISO template and as a Word document as other formats will not be accepted.

Those regarding IEC documents should be sent to Tony Zertuche, General Secretary, USNC/IEC, at ANSI's New York offices (tzertuche@ansi.org). The final date for offering comments is listed after each draft.

## Ordering Instructions

**ISO and IEC Drafts can be made available by contacting ANSI's Customer Service department. Please e-mail your request for an ISO or IEC Draft to Customer Service at sales@ansi.org. When making your request, please provide the date of the Standards Action issue in which the draft document you are requesting appears.**

## ISO Standards

### **BASES FOR DESIGN OF STRUCTURES (TC 98)**

ISO/DIS 10252, Bases for design of structures - Accidental actions due to human activities - 12/16/2018, \$165.00

### **BIOLOGICAL EVALUATION OF MEDICAL AND DENTAL MATERIALS AND DEVICES (TC 194)**

ISO/DIS 22442-2, Medical devices utilizing animal tissues and their derivatives - Part 2: Controls on sourcing, collection and handling - 12/16/2018, \$71.00

### **BUILDING ENVIRONMENT DESIGN (TC 205)**

ISO/DIS 19454, Building environment design - Indoor environment - Daylight opening design for sustainability principles in visual environment - 10/19/2018, \$88.00

### **DOCUMENT IMAGING APPLICATIONS (TC 171)**

ISO/DIS 18759, Document management - Trusted Storage Sub-System (TSS) functional and technical requirements - 10/19/2018, \$82.00

### **ENVIRONMENTAL MANAGEMENT (TC 207)**

ISO/DIS 14007, Environmental management - Guidelines for determining environmental costs and benefits - 10/19/2018, \$88.00

### **FERROUS METAL PIPES AND METALLIC FITTINGS (TC 5)**

ISO/DIS 21053, Life cycle analysis and recycling of ductile iron pipes for water applications - 10/20/2018, \$53.00

### **FIRE SAFETY (TC 92)**

ISO/DIS 11925-2, Reaction to fire tests - Ignitability of products subjected to direct impingement of flame - Part 2: Single-flame source test - 10/20/2018, \$98.00

### **SHIPS AND MARINE TECHNOLOGY (TC 8)**

ISO/DIS 21593, Ship and marine technology - Technical requirements for liquefied natural gas bunkering dry-disconnect/connect coupling - 10/19/2018, \$67.00

### **STEEL (TC 17)**

ISO/DIS 4987, Steel castings - Liquid penetrant inspection - 10/21/2018, \$112.00

ISO/DIS 19959, Visual examination of the surface condition of investment castings - Steel, nickel alloys and cobalt alloys - 10/19/2018, \$33.00

### **TERMINOLOGY (PRINCIPLES AND COORDINATION) (TC 37)**

ISO/DIS 26162-1, Management of terminology resources - Terminology databases - Part 1: Design - 12/20/2018, \$71.00

ISO/DIS 26162-2, Management of terminology resources - Terminology databases - Part 2: Software - 12/20/2018, \$58.00

### **TEXTILES (TC 38)**

ISO/DIS 21701, Textiles - Test method for accelerated hydrolysis of textile materials and biodegradation under controlled composting conditions of the resulting hydrolysate - 12/21/2018, \$53.00

### **TIMBER (TC 218)**

ISO/DIS 13061-5, Physical and mechanical properties of wood - Test methods for small clear wood specimens - Part 5: Determination of strength in compression perpendicular to grain - 12/11/2002, \$40.00

### **TRACTORS AND MACHINERY FOR AGRICULTURE AND FORESTRY (TC 23)**

ISO/DIS 11783-9, Tractors and machinery for agriculture and forestry - Serial control and communications data network - Part 9: Tractor ECU - 12/20/2018, \$71.00

### **WELDING AND ALLIED PROCESSES (TC 44)**

ISO/DIS 17927-1, Welding for aerospace applications - Fusion welding of metallic components - Part 1: Process specification - 10/19/2018, \$88.00

## IEC Standards

- 5/209/CD, IEC 60953-3 ED2: Rules for steam turbine thermal acceptance tests - Part 3: Thermal performance verification tests of retrofitted steam turbines, /2018/11/2
- 15/857/CDV, IEC 60684-3-214 ED4: Flexible insulating sleeving - Part 3: Specifications for individual types of sleeving - Sheet 214: Heat-shrinkable, polyolefin sleeving, not flame retarded, thick and medium wall, /2018/12/2
- 15/859/CDV, IEC 60684-3-280 ED2: Flexible insulating sleeving - Part 3: Specifications for individual types of sleeving - Sheet 280: Heat-shrinkable, polyolefin sleeving, anti-tracking, /2018/12/2
- 15/860/CDV, IEC 60684-3-283 ED2: Flexible insulating sleeving - Part 3: Specifications for individual types of sleeving - Sheet 283: Heat-shrinkable, polyolefin sleeving for bus-bar insulation, /2018/12/2
- 15/858/CDV, IEC 60684-3-247 ED2: Flexible insulating sleeving - Part 3: Specifications for individual types of sleeving - Sheet 247: Heat-shrinkable, polyolefin sleeving, dual wall, not flame retarded, thick and medium wall, /2018/12/2
- 45A/1232/CD, IEC 61468 ED2: Nuclear power plants - Instrumentation systems important to safety - In-core instrumentation - Characteristics and test methods of self-powered neutron detectors, /2018/12/2
- 59F/358/CDV, IEC 60704-2-17 ED1: Household and similar electrical appliances - Test code for the determination of airborne acoustical noise - Part 2-17: Particular requirements for dry cleaning robots, /2018/12/2
- 59F/359/CDV, IEC 62885-9 ED1: Surface cleaning appliances - Part 9: Floor treatment machines with or without traction drive, for commercial use - Methods of measuring the performance, /2018/12/2
- 59L/161/CDV, IEC 60704-2-8 ED2: Household and similar electrical appliances - Test code for the determination of airborne acoustical noise - Part 2-8: Particular requirements for electric shavers and clippers or trimmers, /2018/12/2
- 79/613/NP, PNW 79-613: Video surveillance systems for use in security applications - Part 2-4: Video transmission protocols - Technical requirements for interconnection protocol for trans-regional video surveillance systems (proposed IEC 62676-2-4), /2018/12/2
- 82/1486/CD, IEC TS 63202-2 ED1: Photovoltaic cells - Part 2: Electroluminescence image for crystalline silicon solar cells, /2018/12/2
- 100/3155/CD, IEC 63181-2 ED1: LCD multi-screen display terminals - Part 2: Measuring methods, /2018/12/2
- 100/3154/CD, IEC TS 63181-1 ED1: LCD multi-screen display terminals - Part 1: Conceptual model, /2018/12/2
- 100/3152/DTS, IEC TS 62871-2 ED1: Professional video storage products - Tape-less camera recorder using MXF file format - Encoding guidelines - Part 2: Mapping MPEG-2 and AVC Streams into MXF (TA 6), /2018/12/2
- 105/709/CD, IEC TS 62282-9-102 ED1: Fuel cell technologies - Part 9 -102: Evaluation methodology for the environmental performance of fuel cell power systems based on life cycle thinking - Product category rules for environmental product declarations of stationary fuel cell power systems and alternative systems for residential applications, /2018/12/2
- 105/706/CD, IEC TS 62282-9-101 ED1: Fuel cell technologies - Part 9 -101: Evaluation methodology for the environmental performance of fuel cell power systems based on life cycle thinking - Streamlined life-cycle considered environmental performance characterization of stationary fuel cell power systems for residential applications, /2018/12/2
- 113/443/CD, IEC TS 62565-4-1 ED1: Nanomanufacturing - Key control characteristics - Part 4-1: Luminescent nanomaterials - Blank detail specification, /2018/12/2
- 116/383/CDV, IEC 62841-3-9 ED2: Electric motor-operated hand-held tools, transportable tools and lawn and garden machinery - Safety - Part 3-9: Particular requirements for transportable mitre saws, /2018/12/2
- 116/385/CDV, IEC 62841-4-3 ED1: Electric motor-operated hand-held tools, transportable tools and lawn and garden machinery - Safety - Part 4-3: Particular requirements for pedestrian controlled walk-behind lawnmowers, /2018/12/2
- 121B/74/FDIS, IEC 61439-7 ED1: Low-voltage switchgear and controlgear assemblies - Part 7: Assemblies for specific applications such as marinas, camping sites, market squares, electric vehicle charging stations, 2018/11/9
- CIS/A/1272/CD, CISPR 16-1-6/AMD2 ED1: Amendment 2 - Specification for radio disturbance and immunity measuring apparatus and methods - Part 1-6: Radio disturbance and immunity measuring apparatus - EMC antenna calibration, /2018/12/2
- JTC1-SC25/2831/NP, PNW JTC1-SC25-2831: Application Protocols for ISO/IEC 14543-4-301 - Home Air Conditioners and Controllers, /2018/12/2



# Newly Published ISO Standards

Listed here are new and revised standards recently approved and promulgated by ISO - the International Organization for Standardization. Most are available at the ANSI Electronic Standards Store (ESS) at [www.ansi.org](http://www.ansi.org). All paper copies are available from Standards resellers (<http://webstore.ansi.org/faq.aspx#resellers>).

## AGRICULTURAL FOOD PRODUCTS (TC 34)

ISO 20377:2018, Dried parsley (*Petroselinum crispum*) - Specification, \$45.00

## AIR QUALITY (TC 146)

ISO 12219-8:2018, Interior air of road vehicles - Part 8: Handling and packaging of materials and components for emission testing, \$68.00

## CARBON DIOXIDE CAPTURE, TRANSPORTATION, AND GEOLOGICAL STORAGE (TC 265)

ISO 27919-1:2018, Carbon dioxide capture - Part 1: Performance evaluation methods for post-combustion CO<sub>2</sub> capture integrated with a power plant, \$209.00

## GEOGRAPHIC INFORMATION/GEOMATICS (TC 211)

ISO 19123-2:2018, Geographic information - Schema for coverage geometry and functions - Part 2: Coverage implementation schema, \$162.00

## INDUSTRIAL AUTOMATION SYSTEMS AND INTEGRATION (TC 184)

ISO 16300-1:2018, Automation systems and integration - Interoperability of capability units for manufacturing application solutions - Part 1: Interoperability criteria of capability units per application requirements, \$68.00

## NUCLEAR ENERGY (TC 85)

ISO 12807:2018, Safe transport of radioactive materials - Leakage testing on packages, \$232.00

## OPTICS AND OPTICAL INSTRUMENTS (TC 172)

ISO 9211-1:2018, Optics and photonics - Optical coatings - Part 1: Vocabulary, \$45.00

## PAINTS AND VARNISHES (TC 35)

ISO 7783:2018, Paints and varnishes - Determination of water-vapour transmission properties - Cup method, \$103.00

ISO 11125-1:2018, Preparation of steel substrates before application of paints and related products - Test methods for metallic blast-cleaning abrasives - Part 1: Sampling, \$68.00

ISO 11125-7:2018, Preparation of steel substrates before application of paints and related products - Test methods for metallic blast-cleaning abrasives - Part 7: Determination of moisture, \$45.00

## PLASTICS (TC 61)

ISO 19935-1:2018, Plastics - Temperature modulated DSC - Part 1: General principles, \$103.00

## POWDER METALLURGY (TC 119)

ISO 4022:2018, Permeable sintered metal materials - Determination of fluid permeability, \$103.00

## ROAD VEHICLES (TC 22)

ISO 6469-3:2018, Electrically propelled road vehicles - Safety specifications - Part 3: Electrical safety, \$138.00

ISO 21266-1:2018, Road vehicles - Compressed gaseous hydrogen (CGH<sub>2</sub>) and hydrogen/natural gas blends fuel systems - Part 1: Safety requirements, \$103.00

ISO 21266-2:2018, Road vehicles - Compressed gaseous hydrogen (CGH<sub>2</sub>) and hydrogen/natural gas blends fuel systems - Part 2: Test methods, \$68.00

## RUBBER AND RUBBER PRODUCTS (TC 45)

ISO 4661-2:2018, Rubber, vulcanized - Preparation of samples and test pieces - Part 2: Chemical tests, \$45.00

ISO 6101-6:2018, Rubber - Determination of metal content by atomic absorption spectrometry - Part 6: Determination of magnesium content, \$68.00

ISO 22762-1:2018, Elastomeric seismic-protection isolators - Part 1: Test methods, \$209.00

ISO 22762-2:2018, Elastomeric seismic-protection isolators - Part 2: Applications for bridges - Specifications, \$209.00

ISO 22762-3:2018, Elastomeric seismic-protection isolators - Part 3: Applications for buildings - Specifications, \$209.00

ISO 24698-1:2018, Rubber, raw - Determination of bound acrylonitrile content in acrylonitrile-butadiene rubber (NBR) - Part 1: Combustion (Dumas) method, \$68.00

## SECURITY (TC 292)

ISO 22381:2018, Security and resilience - Authenticity, integrity and trust for products and documents - Guidelines for establishing interoperability among object identification systems to deter counterfeiting and illicit trade, \$138.00

ISO 22395:2018, Security and resilience - Community resilience - Guidelines for supporting vulnerable persons in an emergency, \$68.00

## SHIPS AND MARINE TECHNOLOGY (TC 8)

ISO 17325-3:2018, Ships and marine technology - Marine environment protection - Oil booms - Part 3: End connectors, \$68.00

**SMALL TOOLS (TC 29)**

ISO 2296:2018, Metal slitting saws with fine and coarse teeth - Metric series, \$45.00

**STEEL (TC 17)**

ISO 10144:2018, Steels for the reinforcement and prestressing of concrete - Certification scheme for steel bars and wires, \$68.00

**TEXTILES (TC 38)**

ISO 20158:2018, Textiles - Determination of water absorption time and water absorption capacity of textile fabrics, \$45.00

ISO 21232:2018, Textiles - Determination of moisturizing effect of textile materials by measurement of microclimate between textiles and simulated human skin using sweating guarded hotplate, \$68.00

**TRACTORS AND MACHINERY FOR AGRICULTURE AND FORESTRY (TC 23)**

ISO 4254-9:2018, Agricultural machinery - Safety - Part 9: Seed drills, \$138.00

**TYRES, RIMS AND VALVES (TC 31)**

ISO 7867-2:2018, Metric series for agricultural, forestry machines and construction tyres - Part 2: Load ratings for agricultural tyres, \$138.00

**ISO Technical Reports****CLEAN COOKSTOVES AND CLEAN COOKING SOLUTIONS (TC 285)**

ISO/TR 19867-3:2018, Clean cookstoves and clean cooking solutions - Harmonized laboratory test protocols - Part 3: Voluntary performance targets for cookstoves based on laboratory testing, \$103.00

**GEARS (TC 60)**

ISO/TR 6336-31:2018, Calculation of load capacity of spur and helical gears - Part 31: Calculation examples of micropitting load capacity, \$185.00

**OPTICS AND OPTICAL INSTRUMENTS (TC 172)**

ISO/TR 20772:2018, Ophthalmic optics - Spectacle lenses - Short wavelength visible solar radiation and the eye, \$162.00

**ISO Technical Specifications****DOCUMENT IMAGING APPLICATIONS (TC 171)**

ISO/TS 19475-1:2018, Document management - Minimum requirements for the storage of documents - Part 1: Capture, \$45.00

ISO/TS 19475-2:2018, Document management - Minimum requirements for the storage of documents - Part 2: Storage, \$45.00

ISO/TS 19475-3:2018, Document management - Minimum requirements for the storage of documents - Part 3: Disposal, \$45.00

**SECURITY (TC 292)**

ISO/TS 22331:2018, Security and resilience - Business continuity management systems - Guidelines for business continuity strategy, \$138.00

ISO/TS 22375:2018, Security and resilience - Guidelines for complexity assessment process, \$162.00

**ISO/IEC JTC 1, Information Technology**

ISO/IEC 11770-2:2018, IT Security techniques - Key management - Part 2: Mechanisms using symmetric techniques, \$162.00

ISO/IEC 23005-2:2018, Information technology - Media context and control - Part 2: Control information, \$232.00

ISO/IEC 23005-4:2018, Information technology - Media context and control - Part 4: Virtual world object characteristics, \$232.00

ISO/IEC 20071-23:2018, Information technology - User interface component accessibility - Part 23: Visual presentation of audio information (including captions and subtitles), \$162.00

**ISO/IEC Guides****OTHER**

ISO/IEC Guide 41:2018, Packaging - Recommendations for addressing consumer needs, \$138.00

# Proposed Foreign Government Regulations

## Call for Comment

U.S. manufacturers, exporters, regulatory agencies and standards developing organizations may be interested in proposed foreign technical regulations notified by Member countries of the World Trade Organization (WTO). In accordance with the WTO Agreement on Technical Barriers to Trade (TBT Agreement), Members are required to notify proposed technical regulations that may significantly affect trade to the WTO Secretariat in Geneva, Switzerland. In turn, the Secretariat issues and makes available these notifications. The purpose of the notification requirement is to provide global trading partners with an opportunity to review and comment on the regulations before they become final.

The USA Inquiry Point for the WTO TBT Agreement is located at the National Institute of Standards and Technology (NIST) in the Standards Coordination Office (SCO). The Inquiry Point distributes the notified proposed foreign technical regulations (notifications) and makes the associated full-texts available to U.S. stakeholders via its online service, Notify U.S. Interested U.S. parties can register with Notify U.S. to receive e-mail alerts when notifications are added from countries and industry sectors of interest to them.

To register for Notify U.S., please visit <http://www.nist.gov/notifyus/>.

The USA WTO TBT Inquiry Point is the official channel for distributing U.S. comments to the network of WTO TBT Enquiry Points around the world. U.S. business contacts interested in commenting on the notifications are asked to review the comment guidance available on Notify U.S. at <https://tsapps.nist.gov/notifyus/data/guidance/guidance.cfm> prior to submitting comments.

For further information about the USA TBT Inquiry Point, please visit: <https://www.nist.gov/standardsgov/what-we-do/trade-regulatory-programs/usa-wto-tbt-inquiry-point>

Contact the USA TBT Inquiry Point at:(301) 975-2918; Fax: (301) 926-1559; E-mail: [usatbtep@nist.gov](mailto:usatbtep@nist.gov) or [notifyus@nist.gov](mailto:notifyus@nist.gov).

# Information Concerning

---

## American National Standards

### Call for Members

#### INCITS Executive Board – ANSI Accredited SDO and US TAG to ISO/IEC JTC 1, Information Technology

The InterNational Committee for Information Technology Standards (INCITS), an ANSI accredited SDO, is the forum of choice for information technology developers, producers and users for the creation and maintenance of formal de jure IT standards. INCITS' mission is to promote the effective use of Information and Communication Technology through standardization in a way that balances the interests of all stakeholders and increases the global competitiveness of the member organizations.

The INCITS Executive Board serves as the consensus body with oversight of its 40+ Technical Committees. Additionally, the INCITS Executive Board has the international leadership role as the US Technical Advisory Group (TAG) to ISO/IEC JTC 1, Information Technology.

Membership in the INCITS Executive Board is open to all directly and materially affected parties in accordance with INCITS membership rules. To find out more about participating on the INCITS Executive Board, contact Jennifer Garner at [jgarner@itic.org](mailto:jgarner@itic.org) or visit <http://www.incits.org/participation/membership-info> for more information.

Membership in all interest categories is always welcome; however, the INCITS Executive Board seeks to broaden its membership base in the following categories:

- Service Providers
- Users
- Standards Development Organizations and Consortia
- Academic Institutions

### Society of Cable Telecommunications

#### ANSI Accredited Standards Developer

SCTE, an ANSI-accredited SDO, is the primary organization for the creation and maintenance of standards for the cable telecommunications industry. SCTE's standards mission is to develop standards that meet the needs of cable system operators, content providers, network and customer premises equipment manufacturers, and all others who have an interest in the industry through a fair, balanced and transparent process.

SCTE is currently seeking to broaden the membership base of its consensus bodies and is interested in new members in all membership categories to participate in new work in fiber-optic networks, advanced advertising, 3D television, and other important topics. Of particular interest is membership from the content (program and advertising) provider and user communities.

Membership in the SCTE Standards Program is open to all directly a materially affected parties as defined in SCTE's membership rules and operating procedures. More information is available at [www.scte.org](http://www.scte.org) or by e-mail from [standards@scte.org](mailto:standards@scte.org).

## ANSI Accredited Standards Developers

### Approval of Reaccreditation

#### National Council for Prescription Drug Programs (NCPDP)

The reaccreditation of the National Council for Prescription Drug Programs (NCPDP), an ANSI member and Accredited Standards Developer (ASD), has been approved at the direction of ANSI's Executive Standards Council, under its recently revised NCPDP Standing Operating Procedures for documenting consensus on NCPDP-sponsored American National Standards, effective October 3, 2018. For additional information, please contact: Ms. Kittye Krempin, Standards Specialist, Standards Development, National Council for Prescription Drug Programs, 9240 East Raintree Drive, Scottsdale, AZ 85260; phone: 480.477.1000, ext. 134; e-mail: [kkrempin@ncpdp.org](mailto:kkrempin@ncpdp.org).

#### Nuclear Information Records and Management Association (NIRMA)

The reaccreditation of the Nuclear Information Records and Management Association (NIRMA), an ANSI member and Accredited Standards Developer (ASD), has been approved at the direction of ANSI's Executive Standards Council, under its recently revised operating procedures for documenting consensus on NIRMA-sponsored American National Standards, effective October 3, 2018. For additional information, please contact: Ms. Sarah Perkins, NIRMA Administrator, Nuclear Information Records and Management Association, 245 Sunnyside Avenue #41, Fairfield, CT 06824; phone: 203.345.7237; e-mail: [nirma@nirma.org](mailto:nirma@nirma.org).

## International Organization for Standardization

### ISO Proposal for a New Field of ISO Technical Activity

#### Sharing Economy

#### Comment Deadline: October 19, 2018

JISC, the ISO member body for Japan, has submitted to ISO a proposal for a new field of ISO technical activity on Sharing Economy, with the following scope statement:

Standardization in the field of sharing economy.

Excluded: Technical aspects of information security or risk management guidelines already covered by ISO/IEC JTC 1/SC27 and ISO/TC 262, respectively.

Anyone wishing to review the proposal can request a copy by contacting ANSI's ISO Team ([isot@ansi.org](mailto:isot@ansi.org)), with a submission of comments to Steve Cornish ([scornish@ansi.org](mailto:scornish@ansi.org)) by close of business on Friday, October 19.



## Meeting Notices

### Association of Challenge Course Technology (ACCT) Consensus Group Meetings

Upcoming conference call meetings of the ACCT Consensus Group will be held on:

- November 14th from 12pm – 1:30pm Mountain time
- December 12th from 12pm – 1:30pm Mountain time
- January 9th from 12pm – 1:30pm Mountain time

Location: ACCT Conference Line

These meetings are open to the public. Persons wishing to attend this meeting are required to pre-register by contacting Shawn Tierney, ACCT Executive Director [shawn@acctinfo.org](mailto:shawn@acctinfo.org) or (303) 827-2432.

### Accredited Standards Committee (ASC) B109 Standards B109.1, B109.2, B109.3, and B109.4

Meeting Date: October 22, 2018; 8:00 AM – 4:00 PM CST

Meeting Location: Omni Forth Worth Hotel, 1300 Houston Street, Fort Worth, Texas (Teleconference information available upon request)

Purpose: This is the annual ANSI B109 meeting. Updates will be given for each of the B109 standards. Breakout sessions for B109.1, B109.2, B109.3, and B109.4 will follow the main meeting.

Please register on line at [www.aga.org](http://www.aga.org). For more information, contact Jeff Meyers, [jmeyers@aga.org](mailto:jmeyers@aga.org).

### National Waste and Recycling Association (NW&RA)

The National Waste and Recycling Association (NW&RA) serves as the secretariat for the ANSI Z245 Committee on Equipment Technology and Operations for Wastes and Recyclable Materials. The next meeting will be on November 13 and 14th in Knoxville, TN. The Z245.1 committee on Mobile Equipment will meet from 13:00 to 15:00 on November 13. The Z245.7 committee on size reduction equipment will be on November 13 from 15:00 to 17:00. On November 14 from 08:00 to 12:00 the Z245.2 and Z245.5 committees on Compactors and Balers, respectively, will be meeting. The location of the meeting is at the Courtyard Knoxville West/Bearden, 250 Brookview Centre Way, Knoxville, TN 37919. Those interested in participating can contact Kirk Sander at [ksander@wasterecycling.org](mailto:ksander@wasterecycling.org) or register for free here:

<https://mx.wasterecycling.org/Events/EventDetails.aspx?MeetingId=%7b430E6FC7-47BC-E811-8D48-0050569142AF%7d>.

# Information Concerning

## International Organization for Standardization (ISO)

### Call for U.S. TAG Administrator

#### **TC 107 – *Metallic and other inorganic coatings* and Subcommittees**

There is currently no ANSI-accredited U.S. TAG Administrator for TC 107, TC 107/SC 3, TC 107/SC 4, TC 107/SC 7, TC 107/SC 8, and TC 107/SC 9, and therefore ANSI is not a member of these committees. The Secretariats for these committees are held by South Korea (KATS) for TC 107, TC 107/SC 3, and TC 107/SC 8; the UK (BSI) for TC 107/SC 4; Japan (JISC) for TC 107/SC 7, and China (SAC) for TC 107/SC 9.

#### **TC 107 operates under the following scope:**

*Standardization of the characteristics of protective and decorative metallic coating applied by electrolysis, fusion, vacuum or chemical means, mechanical deposition, ion plating.*

*Standardization of the characteristics of protective and decorative non-metallic coatings (excluding paints and other organic coatings) on metal surface applied by electrolysis, fusion, vacuum or chemical means.*

*Standardization of testing and inspection methods for such coatings.*

*Standardization of the preparation of the substrates prior to the deposition of metallic and inorganic coatings.*

#### **TC 107/SC 3 operates under the following scope:**

*Electrodeposited coatings and related finishes*

#### **TC 107/SC 4 operates under the following scope:**

*Hot dip coatings (galvanized, etc.)*

#### **TC 107/SC 7 operates under the following scope:**

*Standardization in the field of corrosion and porosity tests of metallic coatings, and non-organic coatings*

#### **TC 107/SC 8 operates under the following scope:**

*Chemical conversion coatings*

**TC 107/SC 9 operates under the following scope:**

*Standardization of the specification of vacuum evaporation, magnetron sputtering, arc ion plating, other new physical vapor deposition methods or their combination as an alternative to conventional electro/electroless plating.*

*Standardization of the characteristics of protective and decorative metallic (such as silver, copper, chrome, titanium and zirconium) or non-metallic coatings (such as nitrides and oxides, excluding paints and other organic coatings as well as diamond-like carbon films).*

*Standardization of the characteristics of inorganic nanocomposite and/or multilayer and multiphase coatings (such as multi-components nitrides and carbides of CrAlN-base, TiAlN-base, TiCN-base, MeN/SiNx, as well as boride of TiB<sub>2</sub> and ZrB<sub>2</sub>) for functional performance (friction and wear, corrosion and oxidation, fatigue and mechanical properties).*

*Standardization of testing and inspection methods for physical vapor deposition coatings and pretreatment methods for metal substrates prior to the deposition.*

Organizations interested in serving as the U.S. TAG Administrator or participating on a U.S. TAG should contact ANSI's ISO Team ([isot@ansi.org](mailto:isot@ansi.org)).

# Information Concerning

## IAPMO Solicits Proposals for 2020 We♠Stand

### Proposal Deadline: January 29, 2019

The International Association of Plumbing and Mechanical Officials (IAPMO), publisher of the Water Efficiency and Sanitation Standard® (WE♠Stand), is calling for formal code proposals toward the development of the 2020 edition of this standard.

The change proposal form, as well as proposal instructions and background on IAPMO's ANSI-accredited consensus process, may be found at <http://www.iapmo.org/WEStand/pages/default.aspx>. All proposals recommending new text, revised text, or the deletion of text must be written in legislative format and clearly state the reason behind the recommendation.

No proposals will be accepted after the 5 p.m. deadline on Jan. 29, 2019.

This standard provides progressive codified requirements to optimize water use practices attributed to the built environment while maintaining protection of the public health, safety, and welfare.

IAPMO will employ a voluntary consensus development process accredited by the American National Standards Institute (ANSI) for the development of WE♠Stand, enabling anyone to have a voice in the development of the standard. The WE♠Stand Technical Committee, charged with the development and ongoing maintenance of WE♠Stand, brings together an impressive and diverse assembly of plumbing and water efficiency experts.

IAPMO urges its members and other interested parties to get involved in the development process to ensure effectiveness in preserving the public health, safety, and welfare. Manufacturers, potential users of the standard, installers and maintainers, labor representatives, design professionals, enforcing authorities, and consumers all benefit from a cooperative effort in developing codes and standards.

For questions about submitting proposals for the WE♠Stand, contact Dan Cole at (708) 995-3009 or [dan.cole@iapmo.org](mailto:dan.cole@iapmo.org); or Maria Bazan at (708) 995-3007 or [maria.bazan@iapmo.org](mailto:maria.bazan@iapmo.org).

supplier to the user shall be documented and communicated by identifying hazards or associated tasks – see clause 8.

When the supplier is not available to participate in the risk assessment process for the machinery, the user assumes this responsibility.

The supplier shall advise the user of the residual risk that may exist at the conclusion of its risk assessment process. The user shall then apply additional risk reduction measures as determined by its risk assessment. Risk that is transferred between the supplier and user shall be documented and communicated by identifying tasks and their associated hazards – see clause 8 and Annex E.

*Informative Note:* Suppliers and users should collaborate on the risk assessment process, to attain the goal of acceptable risk. Effective communication between suppliers and users is recommended where possible.

### 4.3 Responsibilities of the component supplier, machine supplier and the machine user

The component supplier, machine supplier and the machine user shall be responsible for achieving acceptable risk within the scope of their work activity.

*Informative Note 1:* In general the component supplier is responsible for the design and manufacture of the component it supplies, but not for how the component is integrated in a machine or how it is used / maintained.

*Informative Note 2:* In general, the machine supplier is responsible for the design and manufacture of the machine it supplies including the integration of the component parts it selects, but not for the design and manufacture of the components themselves or for how the machine is used / maintained.

*Informative Note 3:* In general, the machine user is responsible for how the machine is operated and maintained, but not for the design or construction of the machine or the components.

*Informative Note 4:* If more than one entity is involved in the design, construction, integration or installation of the machine, each entity is responsible for the scope of its work activity.

### 4.4 Responsibilities of the component user / machine supplier

#### 4.4.1 Integration

The machine supplier shall determine what risk reduction measures, if any, are required to achieve acceptable risk with any components it integrates into the machine.

*Informative Note:* Particular attention should be paid to instances where safeguards are removed from individual components in order to achieve the desired integration.

#### 4.4.2 Documentation

The machine supplier shall obtain documentation from the component supplier as required for the component(s), including installation requirements, operating instructions, and maintenance requirements.

*Informative Note:* The documentation should include the following, where applicable:

- performance specifications;
- electrical or fluid power schematics and diagrams;
- physical environment for which the component was designed;
- function and location of the operator controls, indicators, and displays;
- schedules for periodic maintenance, lubrication and inspection;
- signs and warnings.

See also, ANSI Z535.6 for additional guidance.

The documentation should include the following, where applicable:

- performance specifications;
- electrical or fluid power schematics and diagrams;
- physical environment for which the device was designed;
- function and location of the operator controls, indicators, and displays;
- schedules for periodic maintenance, lubrication and inspection;
- signs and warnings.

The component part supplier shall furnish documentation as required for the risk reduction measure, including installation requirements, operating instructions, and maintenance requirements.

#### 4.4.3 Risk reduction measures supplied with the component

When a risk reduction measure is supplied with the component, the component user / machine supplier shall be responsible for ensuring that it is integrated, and installed in accordance with the requirements of this standard.

*Informative Note:* The component user / machine supplier should consider the component supplier's performance specifications, schematics, and diagrams, operating and maintenance instructions and warnings when installing, operating, and maintaining the component.

When components are ordered/purchased without safeguards, the component user / machine supplier shall provide risk reduction measure based on a risk assessment and as determined by this standard. ~~and any applicable B11 standard.~~

#### 4.5 Qualified persons

Suppliers and users shall involve qualified persons/subject matter experts in meeting the requirements of this standard. Qualified persons shall be knowledgeable in the applicable standards and codes for the specific application and location of the installation.

*Informative Note:* Although an individual may be responsible for coordinating the analysis, a team of contributors (e.g., operators, maintenance or engineering personnel) should participate in the risk assessment and reduction effort(s).

#### 4.6 Specifications

The user shall communicate its specific safety requirements as part of the machinery purchase. The supplier and user shall develop an agreed upon set of specifications suited to the location and application specifics of the machinery.

*Informative Note 1:* Users should inform the machine supplier if the material to be processed can create an explosive, combustible or hazardous atmosphere or products, or if the machine will be operated in a hazardous (classified) location. See clause 2 and Bibliography for additional information.

*Informative Note 2:* Users should inform the machine supplier of hygienic design requirements. See PMMI B155 TR3 and ISO 14159.

#### 4.7 Design, construction and information for operation and maintenance

The supplier shall use the risk assessment process in designing, constructing and developing the information for operation and maintenance of the machinery.

#### 4.8 Installation, commissioning and start-up

Within the scope of their respective work activities, the user and supplier shall ensure that the risks associated with the installation, commissioning and start-up of the machinery are reduced to an acceptable level.

The installation, commissioning and start-up shall be accomplished in accordance with, but not limited to, the following:

- supplier instructions;
- appropriate regulatory standards;
- accepted industry practices as detailed in applicable standards;
- user installation instructions.

The user shall verify all safety functions of the machinery during commissioning.

#### 4.9 Risk reduction measures

The supplier shall provide risk reduction measure(s) as determined in the supplier risk assessment. The user shall ensure that additional risk reduction measure(s) are provided and installed as determined in the user risk assessment. The user shall ensure that risk reduction measure(s) are properly used, maintained and functional.

#### 4.10 Operation and maintenance

The user shall ensure that the risk level is maintained at an acceptable level during the operation and maintenance of the machinery. The user shall operate and maintain the machinery within the established operating limits and consistent with the supplier instructions for operation and maintenance.

*Informative Note:* Operation includes, but is not limited to activities such as startup, shutdown, clearance, unexpected fault (power outage, shutdown under load)

**AMERICAN NATIONAL STANDARD****ANSI/PMMI B155.1-2016**

The nameplate should be permanent and remain legible throughout the expected life of the machinery.

Nameplate placement and means of attachment shall not increase the risks of hygienic contamination.

**8.5 Information for personal protective equipment (PPE)**

The machinery supplier shall inform the users of any machinery specific PPE requirements.

**8.6 Information for verification**

The machinery supplier shall inform the users of any need and methods to verify or re-verify the risk reduction measures of the machinery.

*Informative Note:* See Annex J for a sample statement of conformity.

**9 Training**

The supplier shall provide materials or information in the manual for the user to incorporate into its training program(s) (see clause 8). Where training materials or information are not available, the user shall develop appropriate training materials or obtain them from other sources.

**9.1 General**

All personnel shall be trained to perform the functions for which they are responsible.

Users shall ensure that personnel working with machines are properly trained in safe working procedures and are qualified to perform the functions to which they are assigned.

*Informative Note:* The user should refer to the supplier's recommendations when establishing a training program.

Examples of training program elements include:

- description of the assigned task;
- hazards associated with the assigned task;
- designated method of risk reduction;
- function of operator controls to be encountered in performing the assigned task;
- methods of function-testing or otherwise assuring the proper function of risk reduction.

As required by assigned functions, personnel shall be trained in the safe working procedures for lockout/tagout/verify of hazardous energy sources. See ANSI Z244.1.

*Informative Note:* See also, 29 CFR 1910.147 and 1910.333.

**9.2 Training elements****9.2.1 General**

Training shall include identification of hazards associated with tasks performed in the installation, set-up, operation, cleaning, and maintenance of machines or machinery systems.

*Informative Note:* The training should focus on hazards associated with personnel actions necessary to perform required tasks on the machinery. Some tasks are more hazardous than others.

Training shall include the identification and proper use of appropriate risk reduction measures necessary to reduce the risk of injury to personnel. **Personnel who operate, maintain or supervise the machinery shall receive regularly scheduled refresher training.**

The requirements for personal protective equipment shall be determined. Personnel shall be trained in the proper donning/doffing, use and maintenance of this equipment and such use shall be enforced by the user.

Training shall include the following as appropriate:

- the functions and locations of manually operated controls;
- safe methods for installing, removing, and adjusting tooling;
- the location of all emergency stop devices;
- the location and method for installation and adjustment of all protective devices and guards;
- the use of safety procedures (e.g., fire prevention equipment);
- procedures for maintaining a safe work area;
- procedures for inspecting and maintaining machinery systems;
- procedures for sanitizing machinery systems;

- the proper method for each production set-up;
- procedures to safely perform necessary tasks that require personnel to be inside the machine envelope with the energy enabled;
- require that all operators demonstrate their knowledge of the proper operation of the machine.

**Informative Note 1:** *The user should place particular emphasis on the training, instruction, and supervision of workers who are inexperienced in the operation of the machine or have difficulty communicating.*

**Informative Note 2:** *Instructions should include guidelines to ensure that:*

- *all personnel are in a safe location before operating the machine;*
- *operators know and understand the startup and stopping procedures;*
- *operators know and understand the safe working procedures established by the user;*
- *operators know the risk reduction required for the operation and understand its function;*
- *operators know they should report to their supervisor any apparent defect, damage, malfunction or inconsistent or unpredictable performance of the machine.*

### 9.2.2 Training program(s)

A training program(s) shall be developed for machines.

Training shall be in the English language or in the official, native or predominant language as determined by the user.

Aspects of the training program shall include:

- a) Information on the risk reduction measures used;

**Informative Note:** *Topics may include but are not limited to:*

- *types of safeguarding devices;*
- *capabilities/options of safeguarding devices;*
- *description of devices selected for a specific application;*
- *function of the selected devices;*
- *functional test of the device;*
- *limitations of the selected device.*

- b) Task/hazard combinations associated with the system;

- c) System set-up;

**Informative Note:** *Topics may include but are not limited to:*

- *procedures for all set-ups;*
- *procedures for changing, replacing and adjusting fixtures/tooling;*
- *transport, and storage of fixtures/tooling;*
- *hazards associated with alternate means of risk reduction.*

- d) System operation;

**Informative Note:** *Topics may include but are not limited to:*

- *machine startup;*
- *machine shutdown;*
- *machine tasks;*
- *hazards related to each task;*
- *response to abnormal/unexpected events;*
- *recovery of operation;*
- *use of auxiliary equipment.*

- e) System maintenance;

**Informative Note:** *Topics may include but are not limited to:*

- *applicable system training;*
- *emergency operations;*
- *hazards associated with:*
  - *preventive maintenance/calibrations;*
  - *troubleshooting;*
  - *repair;*
  - *operational checks;*
  - *malfunctioning safety devices;*
  - *malfunctioning communication systems;*
  - *process variables;*
  - *process materials;*





**BSR/ASHRAE Addendum q to  
ANSI/ASHRAE Standard 34-2016**

**Public Review Draft**

# **Proposed Addendum q to Standard 34-2016, Designation and Safety Classification of Refrigerants**

**First Public Review (September 2018)  
(Draft shows Proposed Changes to Current Standard)**

This draft has been recommended for public review by the responsible project committee. To submit a comment on this proposed standard, go to the ASHRAE website at <https://www.ashrae.org/technical-resources/standards-and-guidelines/public-review-drafts> and access the online comment database. The draft is subject to modification until it is approved for publication by the Board of Directors and ANSI. Until this time, the current edition of the standard (as modified by any published addenda on the ASHRAE website) remains in effect. The current edition of any standard may be purchased from the ASHRAE Online Store at [www.ashrae.org/bookstore](http://www.ashrae.org/bookstore) or by calling 404-636-8400 or 1-800-727-4723 (for orders in the U.S. or Canada).

This standard is under continuous maintenance. To propose a change to the current standard, use the change submittal form available on the ASHRAE website, [www.ashrae.org](http://www.ashrae.org).

The appearance of any technical data or editorial material in this public review document does not constitute endorsement, warranty, or guaranty by ASHRAE of any product, service, process, procedure, or design, and ASHRAE expressly disclaims such.

© 2017 ASHRAE. This draft is covered under ASHRAE copyright. Permission to reproduce or redistribute all or any part of this document must be obtained from the ASHRAE Manager of Standards, 1791 Tullie Circle, NE, Atlanta, GA 30329. Phone: 404-636-8400, Ext. 1125. Fax: 404-321-5478. E-mail: [standards.section@ashrae.org](mailto:standards.section@ashrae.org).

**ASHRAE, 1791 Tullie Circle, NE, Atlanta GA 30329-2305**

BSR/ASHRAE Addendum q to ANSI/ASHRAE Standard 34-2016, *Designation and Safety Classification of Refrigerants*

First Public Review Draft

**(This foreword is not part of this standard. It is merely informative and does not contain requirements necessary for conformance to the standard. It has not been processed according to the ANSI requirements for a standard and may contain material that has not been subject to public review or a consensus process. Unresolved objectors on informative material are not offered the right to appeal at ASHRAE or ANSI.)**

## FOREWORD

*This addendum moves the cis (E) and trans (Z) isomer description from section 4.1.10 (isomers of propene series) to a new standalone section (4.1.13)*

*[Note to Reviewers: This addendum makes proposed changes to the current standard. These changes are indicated in the text by underlining (for additions) and ~~striketrough~~ (for deletions) except where the reviewer instructions specifically describe some other means of showing the changes. Only these changes to the current standard are open for review and comment at this time. Additional material is provided for context only and is not open for comment except as it relates to the proposed changes.]*

## Addendum q to 34-2016

---

**4.1.10** In the case of isomers of the propene series, each has the same number, with the isomers distinguished by two appended lowercase letters. The first appended letter indicates the substitution on the central carbon atom (C2):

—Cl	x
—F	y
—H	z

The second letter designates the substitution on the terminal methylene carbon as defined for the methylene carbon of the propane, consistent with the methodology described in Section 4.1.9:

=CCl <sub>2</sub>	a
=CClF	b
=CF <sub>2</sub>	c
=CHCl	d
=CHF	e
=CH <sub>2</sub>	f

~~In the case where stereoisomers can exist, the opposed (Entgegen or trans) isomer will be identified by the suffix (E) and the same side (Zusammen or cis) isomer will be identified by the suffix (Z). An example of this system is given in Informative Appendix A, Table A-3.~~

**4.1.13** In the case where stereoisomers can exist, the opposed (Entgegen or trans) isomer will be identified by the suffix (E) and the same side (Zusammen or cis) isomer will be identified by the suffix (Z). An example of this system is given in Table A-3 of Informative Appendix A.



**BSR/ASHRAE Addendum r to  
ANSI/ASHRAE Standard 34-2016**

**Public Review Draft**

# **Proposed Addendum r to Standard 34-2016, Designation and Safety Classification of Refrigerants**

**First Public Review (September 2018)  
(Draft shows Proposed Changes to Current Standard)**

This draft has been recommended for public review by the responsible project committee. To submit a comment on this proposed standard, go to the ASHRAE website at <https://www.ashrae.org/technical-resources/standards-and-guidelines/public-review-drafts> and access the online comment database. The draft is subject to modification until it is approved for publication by the Board of Directors and ANSI. Until this time, the current edition of the standard (as modified by any published addenda on the ASHRAE website) remains in effect. The current edition of any standard may be purchased from the ASHRAE Online Store at [www.ashrae.org/bookstore](http://www.ashrae.org/bookstore) or by calling 404-636-8400 or 1-800-727-4723 (for orders in the U.S. or Canada).

This standard is under continuous maintenance. To propose a change to the current standard, use the change submittal form available on the ASHRAE website, [www.ashrae.org](http://www.ashrae.org).

The appearance of any technical data or editorial material in this public review document does not constitute endorsement, warranty, or guaranty by ASHRAE of any product, service, process, procedure, or design, and ASHRAE expressly disclaims such.

© 2017 ASHRAE. This draft is covered under ASHRAE copyright. Permission to reproduce or redistribute all or any part of this document must be obtained from the ASHRAE Manager of Standards, 1791 Tullie Circle, NE, Atlanta, GA 30329. Phone: 404-636-8400, Ext. 1125. Fax: 404-321-5478. E-mail: [standards.section@ashrae.org](mailto:standards.section@ashrae.org).

**ASHRAE, 1791 Tullie Circle, NE, Atlanta GA 30329-2305**

BSR/ASHRAE Addendum r to ANSI/ASHRAE Standard 34-2016, *Designation and Safety Classification of Refrigerants*

First Public Review Draft

**(This foreword is not part of this standard. It is merely informative and does not contain requirements necessary for conformance to the standard. It has not been processed according to the ANSI requirements for a standard and may contain material that has not been subject to public review or a consensus process. Unresolved objectors on informative material are not offered the right to appeal at ASHRAE or ANSI.)**

## FOREWORD

*This addendum corrects language to allow for proper naming of molecules containing Iodine.*

*[Note to Reviewers: This addendum makes proposed changes to the current standard. These changes are indicated in the text by underlining (for additions) and ~~strikethrough~~ (for deletions) except where the reviewer instructions specifically describe some other means of showing the changes. Only these changes to the current standard are open for review and comment at this time. Additional material is provided for context only and is not open for comment except as it relates to the proposed changes.]*

## Addendum r to 34-2016

---

### 3. DEFINITIONS OF TERMS

**halocarbon:** as used in this standard, a hydrocarbon derivative containing one or more of the halogens bromine, chlorine, ~~or~~ fluorine, or iodine; hydrogen also may be present.

### 4. NUMBERING OF REFRIGERANTS

**4.1.5** In those instances where bromine (Br) is present in place of part or all of the chlorine, the same rules apply, except that the uppercase letter “B” after the designation for the parent chlorofluoro compound shows the presence of bromine. The number following the letter “B” shows the number of bromine atoms present.

**4.1.6** In those instances where iodine (I) is present in place of part or all of the chlorine, the same rules apply, except that the uppercase letter “I” after the designation for the parent chlorofluoro compound shows the presence of iodine. The number following the letter “I” shows the number of iodine atoms present.

**4.1.67** The number of chlorine (Cl) atoms in the compound is found by subtracting the sum of fluorine (F), bromine (Br), iodine (I) and hydrogen (H) atoms from the total number of atoms that can be connected to the carbon (C) atoms. For saturated refrigerants, this number is  $2n + 2$ , where  $n$  is the number of carbon atoms. The number is  $2n$  for monounsaturated and cyclic-saturated refrigerants.

**4.1.7-8** The carbon atoms shall be numbered sequentially, in order of appearance, with the number “1” assigned to the end carbon with the greatest number of hydrogen substituents (i.e., number of halogenated atoms substituted for hydrogen on the alkane end carbon atoms). In the case where both end carbons of a saturated compound contain the same number of (but different) halogen atoms, the number “1” shall be assigned to the end carbon, defined as having the largest number of bromine, then chlorine, then fluorine, and then iodine atoms. If the compound is an olefin, then the end carbon nearest to the double bond will be assigned the number “1,” as the presence of a double bond in the backbone of the molecule has priority over substituent groups on the molecule.

**4.1.89** In the case of isomers in the ethane series, each has the same number, with the most symmetrical one indicated by the number alone. As the isomers become more and more unsymmetrical, successive lowercase letters (e.g., “a,” “b,” or “c”) are appended. Symmetry is determined by first summing the atomic mass of the halogen and hydrogen atoms attached to each carbon atom. One sum is subtracted from the other; the smaller the absolute value of the difference, the more symmetrical the isomer. For an example of this system, see Informative Appendix A.

**4.1.9-10** In the case of isomers of the propene series, each has the same number, with the isomers distinguished by two appended lowercase letters. The first appended letter indicates the substitution on the central carbon atom (C2):

—Cl	x
—F	y
—H	z

The second letter designates the substitution on the terminal methylene carbon as defined for the methylene carbon of the propane, consistent with the methodology described in Section 4.1.9:

=CCl <sub>2</sub>	a
=CClF	b

=CF <sub>2</sub>	c
=CHCl	d
=CHF	e
=CH <sub>2</sub>	f

In the case where stereoisomers can exist, the opposed (Entgegen or trans) isomer will be identified by the suffix (E) and the same side (Zusammen or cis) isomer will be identified by the suffix (Z). An example of this system is given in Informative Appendix A, Table A-3.

**4.1.10-11** In the case of isomers of the propene series, each has the same number, with the isomers distinguished by two appended lowercase letters. The first appended letter indicates the substitution on the central carbon atom (C2):

—Cl	x
—F	y
—H	z

The second letter designates the substitution on the terminal methylene carbon as defined for the methylene carbon of the propane, consistent with the methodology described in Section 4.1.9 10:

=CCl <sub>2</sub>	a
=CClF	b
=CF <sub>2</sub>	c
=CHCl	d
=CHF	e
=CH <sub>2</sub>	f

In the case where stereoisomers can exist, the opposed (Entgegen or trans) isomer will be identified by the suffix (E) and the same side (Zusammen or cis) isomer will be identified by the suffix (Z). An example of this system is given in Informative Appendix A, Table A-3.

**4.1.11-12 Extension to Compounds of Four Carbon Atoms.** Compounds are coded according to the above stated rules, with the designation number followed by a set of letters indicating structure. The number of unsaturated linkages is given in the fourth digit from the right. When the number for a digit place exceeds nine, it is set off by dashes. Linear compounds are lettered starting at one end, cyclic compounds from a side group, or, if none, from a carbon in the ring as described in Section 4.1.9 10. Carbon atoms with two hydrogens or halogens are lettered as in Section 4.1.9 10. Carbon atoms with three hydrogen or halogen atom substituents are lettered as shown below:

—CCl <sub>3</sub>	j
—CCl <sub>2</sub> F	k
—CClF <sub>2</sub>	l
—CF <sub>3</sub>	m
—CHCl <sub>2</sub>	n
—CH <sub>2</sub> Cl	o
—CHF <sub>2</sub>	p
—CH <sub>2</sub> F	q
—CHClF	r
—CH <sub>3</sub>	s

Only as many letters are used as are required to completely define the compound when taken with the empirical structure given by the numerical designation. It is understood that no branching occurs in the remaining structure. After the starting point, side groups are given their letters before the backbone substituent (if any). When two or more lettering sequences may be applied, that with the fewest letters and first alphabetical sequence is used.

**4.1.12 13** Bromine or iodine containing, propane-series isomers cannot be uniquely designated by this system.

## 5. DESIGNATION

**5.2 Identification.** Refrigerants shall be identified in accordance with Section 5.2.1, 5.2.2, or 5.2.3. Section 5.2.1 shall be used in technical publications (for international uniformity and to preserve archival consistency), on equipment nameplates, and in specifications. Section 5.2.2 can be used for single component halocarbon refrigerants, where distinction between the presence or absence of chlorine, ~~or~~ bromine or iodine is pertinent. Composition designation may be appropriate for nontechnical, public, and regulatory communications addressing compounds having environmental impact, such as ozone depletion or global warming potential. Section 5.2.3 can be used, under the same circumstances as Section 5.2.2, for blends (both azeotropic and zeotropic). Section 5.2.1 shall be used for miscellaneous organic and inorganic compounds.

**5.2.2 Composition Designating Prefixes.** The identifying number, as determined by Section 4, shall be prefixed by the letter “C” for carbon and preceded by “B,” “C,” ~~or~~ “F” or “I” - or a combination thereof in this sequence—to signify the presence of bromine, chlorine, ~~or~~ fluorine, or iodine respectively. Compounds that also contain hydrogen shall be further preceded by the letter “H” to signify the increased deterioration potential before reaching the stratosphere<sup>6</sup>. The compositional designating prefixes for ether shall substitute an “E” for “C,” such that “HFE,” “HCFE,” and “CFE” refer to hydrofluoroethers, hydrochloroethers, and chloroethers, respectively.



**BSR/ASHRAE Addendum s to  
ANSI/ASHRAE Standard 34-2016**

**Public Review Draft**

**Proposed Addendum s to  
Standard 34-2016, Designation and  
Safety Classification of Refrigerants**

**First Public Review (September 2018)  
(Draft shows Proposed Changes to Current Standard)**

This draft has been recommended for public review by the responsible project committee. To submit a comment on this proposed standard, go to the ASHRAE website at <https://www.ashrae.org/technical-resources/standards-and-guidelines/public-review-drafts> and access the online comment database. The draft is subject to modification until it is approved for publication by the Board of Directors and ANSI. Until this time, the current edition of the standard (as modified by any published addenda on the ASHRAE website) remains in effect. The current edition of any standard may be purchased from the ASHRAE Online Store at [www.ashrae.org/bookstore](http://www.ashrae.org/bookstore) or by calling 404-636-8400 or 1-800-727-4723 (for orders in the U.S. or Canada).

This standard is under continuous maintenance. To propose a change to the current standard, use the change submittal form available on the ASHRAE website, [www.ashrae.org](http://www.ashrae.org).

The appearance of any technical data or editorial material in this public review document does not constitute endorsement, warranty, or guaranty by ASHRAE of any product, service, process, procedure, or design, and ASHRAE expressly disclaims such.

© 2017 ASHRAE. This draft is covered under ASHRAE copyright. Permission to reproduce or redistribute all or any part of this document must be obtained from the ASHRAE Manager of Standards, 1791 Tullie Circle, NE, Atlanta, GA 30329. Phone: 404-636-8400, Ext. 1125. Fax: 404-321-5478. E-mail: [standards.section@ashrae.org](mailto:standards.section@ashrae.org).

**ASHRAE, 1791 Tullie Circle, NE, Atlanta GA 30329-2305**

BSR/ASHRAE Addendums to ANSI/ASHRAE Standard 34-2016, *Designation and Safety Classification of Refrigerants*

First Public Review Draft

**(This foreword is not part of this standard. It is merely informative and does not contain requirements necessary for conformance to the standard. It has not been processed according to the ANSI requirements for a standard and may contain material that has not been subject to public review or a consensus process. Unresolved objectors on informative material are not offered the right to appeal at ASHRAE or ANSI.)**

## FOREWORD

*This addendum adds the single component refrigerant R-1336mzz(E) in Table 4-1.*

*[Note to Reviewers: This addendum makes proposed changes to the current standard. These changes are indicated in the text by underlining (for additions) and ~~striketrough~~ (for deletions) except where the reviewer instructions specifically describe some other means of showing the changes. Only these changes to the current standard are open for review and comment at this time. Additional material is provided for context only and is not open for comment except as it relates to the proposed changes.]*

## Addendum s to 34-2016

---

Add the following underlined data to Table 4-1

### TABLE 4-1 Refrigerant Data and Safety Classifications

Refrigerant Number = R-1336mzz(E)  
 Chemical Name = trans-1,1,1,4,4,4-hexafluoro-2-butene  
 Chemical Formula = CF<sub>3</sub>CH=CHCF<sub>3</sub>  
 OEL = 400 ppm v/v  
 Safety Group = A1  
 RCL = 7,200 ppm v/v; 3.0 lb/Mcf; 48 g/m<sup>3</sup>  
 Highly Toxic or Toxic Under Code Classification = Neither

-----  
 The following data will be added to informative Tables D-1 and E-1 and are not open for comment in the public review.

### TABLE D-1 Refrigerant Data

Refrigerant Number = R-1336mzz(E)  
 Chemical Name = trans-1,1,1,4,4,4-hexafluoro-2-butene  
 Chemical Formula = CF<sub>3</sub>CH=CHCF<sub>3</sub>  
 Molecular Mass = 164.1 g/mol  
 Normal Boiling Point (°F) = 45.3  
 Normal Boiling Point (°C) = 7.4

### TABLE E-1 Toxicity Table for Standard 34

Refrigerant R- = 1336mzz(E)  
 Chemical Name = trans-1,1,1,4,4,4-hexafluoro-2-butene  
 LC<sub>50</sub> = 25,400  
 Cardiac Sensitization LOEL = ND  
 Cardiac Sensitization NOEL = 14,600

Anesthesia EC<sub>50</sub> = ND  
Anesthesia LOEL = ND  
Anesthesia NOEL = 7,200  
Other = ND  
ATEL = 7,200  
ODL = 140,000  
FCL = ND  
RCL = 7,200  
LFL = ND  
ATEL Source = Mortality  
RCL Source = ATEL





**BSR/ASHRAE Addendum t to  
ANSI/ASHRAE Standard 34-2016**

**Public Review Draft**

# **Proposed Addendum t to Standard 34-2016, Designation and Safety Classification of Refrigerants**

**First Public Review (September 2018)  
(Draft shows Proposed Changes to Current Standard)**

This draft has been recommended for public review by the responsible project committee. To submit a comment on this proposed standard, go to the ASHRAE website at <https://www.ashrae.org/technical-resources/standards-and-guidelines/public-review-drafts> and access the online comment database. The draft is subject to modification until it is approved for publication by the Board of Directors and ANSI. Until this time, the current edition of the standard (as modified by any published addenda on the ASHRAE website) remains in effect. The current edition of any standard may be purchased from the ASHRAE Online Store at [www.ashrae.org/bookstore](http://www.ashrae.org/bookstore) or by calling 404-636-8400 or 1-800-727-4723 (for orders in the U.S. or Canada).

This standard is under continuous maintenance. To propose a change to the current standard, use the change submittal form available on the ASHRAE website, [www.ashrae.org](http://www.ashrae.org).

The appearance of any technical data or editorial material in this public review document does not constitute endorsement, warranty, or guaranty by ASHRAE of any product, service, process, procedure, or design, and ASHRAE expressly disclaims such.

© 2017 ASHRAE. This draft is covered under ASHRAE copyright. Permission to reproduce or redistribute all or any part of this document must be obtained from the ASHRAE Manager of Standards, 1791 Tullie Circle, NE, Atlanta, GA 30329. Phone: 404-636-8400, Ext. 1125. Fax: 404-321-5478. E-mail: [standards.section@ashrae.org](mailto:standards.section@ashrae.org).

**ASHRAE, 1791 Tullie Circle, NE, Atlanta GA 30329-2305**

BSR/ASHRAE Addendum t to ANSI/ASHRAE Standard 34-2016, *Designation and Safety Classification of Refrigerants*

First Public Review Draft

**(This foreword is not part of this standard. It is merely informative and does not contain requirements necessary for conformance to the standard. It has not been processed according to the ANSI requirements for a standard and may contain material that has not been subject to public review or a consensus process. Unresolved objectors on informative material are not offered the right to appeal at ASHRAE or ANSI.)**

## FOREWORD

*This addendum adds the single component refrigerant R-131I in Table 4-1.*

*[Note to Reviewers: This addendum makes proposed changes to the current standard. These changes are indicated in the text by underlining (for additions) and ~~striketrough~~ (for deletions) except where the reviewer instructions specifically describe some other means of showing the changes. Only these changes to the current standard are open for review and comment at this time. Additional material is provided for context only and is not open for comment except as it relates to the proposed changes.]*

## Addendum t to 34-2016

---

Add the following underlined data to Table 4-1

### TABLE 4-1 Refrigerant Data and Safety Classifications

Refrigerant Number = R-131I  
 Chemical Name = trifluoroiodomethane  
 Chemical Formula = CF3I  
 OEL = 500 ppm v/v  
 Safety Group = A1  
 RCL = 2,000 ppm v/v; 1.0 lb/Mcf; 16 g/m<sup>3</sup>  
 Highly Toxic or Toxic Under Code Classification = Neither

-----  
 The following data will be added to informative Tables D-1 and E-1 and are not open for comment in the public review.

### TABLE D-1 Refrigerant Data

Refrigerant Number = R-131I  
 Chemical Name = trifluoroiodomethane  
 Chemical Formula = CF3I  
 Molecular Mass = 195.9 g/mol  
 Normal Boiling Point (°F) = -7.4  
 Normal Boiling Point (°C) = -21.9

### TABLE E-1 Toxicity Table for Standard 34

Refrigerant R- = 131I  
 Chemical Name = trifluoroiodomethane  
 LC<sub>50</sub> = 128,000  
 Cardiac Sensitization LOEL = ND  
 Cardiac Sensitization NOEL = 2,000  
 Anesthesia EC<sub>50</sub> = ND  
 Anesthesia LOEL = ND

Anesthesia NOEL = 10,000

Other = ND

ATEL = 2,000

ODL = 140,000

FCL = ND

RCL = 2,000

LFL = ND

ATEL Source = Cardiac Sensitization

RCL Source = ATEL



**BSR/ASHRAE Addendum u to  
ANSI/ASHRAE Standard 34-2016**

**Public Review Draft**

# **Proposed Addendum u to Standard 34-2016, Designation and Safety Classification of Refrigerants**

**First Public Review (September 2018)  
(Draft shows Proposed Changes to Current Standard)**

This draft has been recommended for public review by the responsible project committee. To submit a comment on this proposed standard, go to the ASHRAE website at <https://www.ashrae.org/technical-resources/standards-and-guidelines/public-review-drafts> and access the online comment database. The draft is subject to modification until it is approved for publication by the Board of Directors and ANSI. Until this time, the current edition of the standard (as modified by any published addenda on the ASHRAE website) remains in effect. The current edition of any standard may be purchased from the ASHRAE Online Store at [www.ashrae.org/bookstore](http://www.ashrae.org/bookstore) or by calling 404-636-8400 or 1-800-727-4723 (for orders in the U.S. or Canada).

This standard is under continuous maintenance. To propose a change to the current standard, use the change submittal form available on the ASHRAE website, [www.ashrae.org](http://www.ashrae.org).

The appearance of any technical data or editorial material in this public review document does not constitute endorsement, warranty, or guaranty by ASHRAE of any product, service, process, procedure, or design, and ASHRAE expressly disclaims such.

© 2017 ASHRAE. This draft is covered under ASHRAE copyright. Permission to reproduce or redistribute all or any part of this document must be obtained from the ASHRAE Manager of Standards, 1791 Tullie Circle, NE, Atlanta, GA 30329. Phone: 404-636-8400, Ext. 1125. Fax: 404-321-5478. E-mail: [standards.section@ashrae.org](mailto:standards.section@ashrae.org).

**ASHRAE, 1791 Tullie Circle, NE, Atlanta GA 30329-2305**

BSR/ASHRAE Addendum u to ANSI/ASHRAE Standard 34-2016, *Designation and Safety Classification of Refrigerants*

First Public Review Draft

**(This foreword is not part of this standard. It is merely informative and does not contain requirements necessary for conformance to the standard. It has not been processed according to the ANSI requirements for a standard and may contain material that has not been subject to public review or a consensus process. Unresolved objectors on informative material are not offered the right to appeal at ASHRAE or ANSI.)**

## FOREWORD

*This addendum adds the zeotropic refrigerant blend R-466A in Table 4-2.*

*[Note to Reviewers: This addendum makes proposed changes to the current standard. These changes are indicated in the text by underlining (for additions) and ~~striketrough~~ (for deletions) except where the reviewer instructions specifically describe some other means of showing the changes. Only these changes to the current standard are open for review and comment at this time. Additional material is provided for context only and is not open for comment except as it relates to the proposed changes.]*

## Addendum u to 34-2016

---

Add the following underlined data to Table 4-2 in the columns indicated.

### TABLE 4-2 Data and Safety Classifications for Refrigerant Blends

Refrigerant Number = 466A  
 Composition (Mass %) = R-32 / 125 / 131I (49.0 / 11.5 / 39.5)  
 Composition tolerances = +0.5, -2.0 / +2.0, -0.5 / +2.0, -0.5  
 OEL = 660  
 Safety Group = A1  
 RCL = 30,000 ppm v/v; 15 lb/Mcf; 240 g/m<sup>3</sup>  
 Highly Toxic or Toxic Under Code Classification = Neither

-----  
 The following data will be added to Informative Table D-2 and is not open for comment in this public review.

### TABLE D-2 Data for Refrigerant Blends

Refrigerant Number = 466A  
 Composition (Mass %) = R-32 / 125 / 131I (49.0 / 11.5 / 39.5)  
 Average Molecular Mass = 80.7 g/mol  
 Bubble Point (°F) = -61.1  
 Bubble Point (°C) = -51.7  
 Dew Point (°F) = -59.8  
 Dew Point (°C) = -51.0



**BSR/ASHRAE Addendum v to  
ANSI/ASHRAE Standard 34-2016**

**Public Review Draft**

# **Proposed Addendum v to Standard 34-2016, Designation and Safety Classification of Refrigerants**

**First Public Review (September 2018)  
(Draft shows Proposed Changes to Current Standard)**

This draft has been recommended for public review by the responsible project committee. To submit a comment on this proposed standard, go to the ASHRAE website at <https://www.ashrae.org/technical-resources/standards-and-guidelines/public-review-drafts> and access the online comment database. The draft is subject to modification until it is approved for publication by the Board of Directors and ANSI. Until this time, the current edition of the standard (as modified by any published addenda on the ASHRAE website) remains in effect. The current edition of any standard may be purchased from the ASHRAE Online Store at [www.ashrae.org/bookstore](http://www.ashrae.org/bookstore) or by calling 404-636-8400 or 1-800-727-4723 (for orders in the U.S. or Canada).

This standard is under continuous maintenance. To propose a change to the current standard, use the change submittal form available on the ASHRAE website, [www.ashrae.org](http://www.ashrae.org).

The appearance of any technical data or editorial material in this public review document does not constitute endorsement, warranty, or guaranty by ASHRAE of any product, service, process, procedure, or design, and ASHRAE expressly disclaims such.

© 2017 ASHRAE. This draft is covered under ASHRAE copyright. Permission to reproduce or redistribute all or any part of this document must be obtained from the ASHRAE Manager of Standards, 1791 Tullie Circle, NE, Atlanta, GA 30329. Phone: 404-636-8400, Ext. 1125. Fax: 404-321-5478. E-mail: [standards.section@ashrae.org](mailto:standards.section@ashrae.org).

**ASHRAE, 1791 Tullie Circle, NE, Atlanta GA 30329-2305**

BSR/ASHRAE Addendum v to ANSI/ASHRAE Standard 34-2016, *Designation and Safety Classification of Refrigerants*

First Public Review Draft

**(This foreword is not part of this standard. It is merely informative and does not contain requirements necessary for conformance to the standard. It has not been processed according to the ANSI requirements for a standard and may contain material that has not been subject to public review or a consensus process. Unresolved objectors on informative material are not offered the right to appeal at ASHRAE or ANSI.)**

## FOREWORD

*This addendum revises paragraph B2.4.1 (Leaks Under Storage/Shipping Conditions) to address fluids whose critical temperature is lower than 130°F(54.4°C).*

*[Note to Reviewers: This addendum makes proposed changes to the current standard. These changes are indicated in the text by underlining (for additions) and ~~striketrough~~ (for deletions) except where the reviewer instructions specifically describe some other means of showing the changes. Only these changes to the current standard are open for review and comment at this time. Additional material is provided for context only and is not open for comment except as it relates to the proposed changes.]*

## Addendum v to 34-2016

---

**B2.4.1 Leaks Under Storage/Shipping Conditions.** To simulate leaks under storage/shipping conditions, the container shall be filled with the WCF to 90%, by mass, of the maximum fill. The maximum fill for fluids having a critical temperature greater than 130°F(54.4°C) is the calculated mass that gives a 100% liquid fill at 130°F (54.4°C). The maximum fill for fluids whose critical temperature is lower than 130°F(54.4°C) is the calculated mass that gives 100% liquid fill at temperature  $T = T_b + 0.8(T_b - T_c)$ , where  $T_b$  is the bubble point temperature at atmospheric pressure (101.3kPa) and  $T_c$  is the fluid critical temperature. The charged blend shall be vapor leaked, 2% by mass of the initial charge per hour, at the following temperatures:

- a. 130°F (54.4°C);
- b. -40.0°F (-40.0°C) or the bubble point at 14.7 psia (101.3 kPa) plus 18.0°F (10.0°C), whichever is warmer; and
- c. the temperature that results in the WCFF between (a) and (b) if the WCFF does not exist at either (a) or (b). If no temperature between (a) and (b) results in the WCFF, then the fractionation test shall instead be conducted at 73.4°F (23.0°C). The applicant shall justify and document what constitutes the temperature at which the WCFF formulation occurs.

In the fractionation experiment, the composition of the head space gas and remaining liquid shall be determined by analysis. Analyses shall be made initially after 2% of the total charge has leaked (vapor leak), next at 10% loss of the initial mass, then at 10% mass loss intervals of the initial mass until atmospheric pressure is reached in the cylinder or no liquid remains. If liquid remains after 90% of the initial mass is lost and atmospheric pressure has not been reached, then the next and last analysis of head space gas and remaining liquid shall be made at 95% mass loss.

Y14.47 DRAFT 03 MAY 2018

**Y14.47 DRAFT 03 MAY 2018**

**ASME Y14.47-201X**

# Model Organization ~~Schema~~ Practices

---

ENGINEERING PRODUCT DEFINITIONS AND RELATED DOCUMENTATION PRACTICES

# DRAFT

TENTATIVE  
SUBJECT TO REVISION OR WITHDRAWAL  
Specific Authorization Required for Reproduction or Quotation  
ASME Standards Certification

THE AMERICAN SOCIETY OF MECHANICAL ENGINEERS  
Two Park Avenue  
New York, New York 10016-5990



Y14.47 DRAFT 03 MAY 2018

## 1.1 Scope

This Standard establishes a schema for organizing [a three dimensional \(3D\) model and other associated information](#) ~~in a 3D model~~ within [the context of](#) a digital product definition data set ~~when for the purpose of~~ conveying [the](#) product definition ~~in that enables~~ a Model-based Enterprise (MBE). This Standard contains no requirements pertaining to drawing graphic sheets. The schema defines a common practice to improve design productivity and to deliver consistent data content and structure to consumers of the data [to facilitate common exchange interfaces](#). ~~This particular schema need not be followed verbatim as long as the producer of the digital product definition data provides a map of the content of the 3D model into the schema.~~

### 3.6 [Attribute](#)

[attribute: a dimension, tolerance, note, text, or symbol required to complete the product definition or feature of the product that is not visible, but available upon interrogation of the annotated model.](#)

### 3.17 Representation

[representation: the manner in which information is stored for interpretation by a machine. the way a concept is modeled as a system of data element\(s\) with corresponding meta-data readable by a machine and computable. \(Derived from NAS9300-007:2007\).](#)

### 3.20 ~~Technical Data Package (TDP)~~

~~technical data package (TDP): a technical description of an item adequate for supporting an acquisition, production, engineering, and logistics support (e.g., Engineering Data for Provisioning, Training, and Technical Manuals). The description defines the required design configuration or performance requirements, and procedures required to ensure adequacy of item performance. It consists of applicable technical data such as models, drawings, associated lists, specifications, standards, performance requirements, QAP, software documentation and packaging details. (MIL-STD-31000A).~~

### 3.19 Acronyms

[AEA = Atomic Energy Act](#)

[DoD = Department of Defense](#)

[DoDI = Department of Defense Issuances](#)

[DLA = Defense Logistics Agency](#)

[EAR = Export Administration Regulations](#)

[ITAR = International Traffic in Arms Regulations](#)

[PIN = Part or Identifying Number](#)

~~QAP = quality assurance provision~~

~~TDP = technical data package~~

## 4.1 General

Most CAD software contains several tools for organizing product data. The schema framework in this Standard provides an organized format when creating the product data for ease of use and [viewing communication to](#) downstream users [and systems](#). Defining data in a consistent manner is necessary for [the viewing communication of](#) shared data.

Y14.47 DRAFT 03 MAY 2018

#### 4.2 Defining a Data Set Using Model-Based Definition

The goal of MBD is to provide complete product definition to downstream users and systems. This means all required engineering information is communicated ~~to all users~~ from one source, the annotated model. Consistency is needed in the creation and presentation of each product to ensure information is communicated effectively. See Fig. 4-1 for an example of an annotated model used in MBD.

MBD is created with all information that facilitates model-specific information extraction, aids in navigating through model data, and provides for or facilitates efficient MBE that uses MBD for the ~~purpose of commission, operation, service, and decommission~~ lifecycle of a product. Maintaining the integrity of model information is the responsibility of anyone who creates or revises the model.

#### 5.1 General

A data set may contain a model or other items that are at different states of completeness. -These states of completeness are may be documented in the data set. ~~The inclusion of the data set completeness states are optional and when used, shall be documented in the data set.~~

#### 6.3 Presentation States

Presentation states shall be used to arrange the presentation of the annotated model for consumption by the user. ~~A Presentation State shall at a minimum include a saved view in accordance with ASME Y14.3.~~

Table 6-1 Examples of Types of Associated Groups That Can Be Used in a Part or Assembly

Group Name	Part	Assembly
Hole patterns	X	<del>...</del> X

Figure 6-X Notes Example

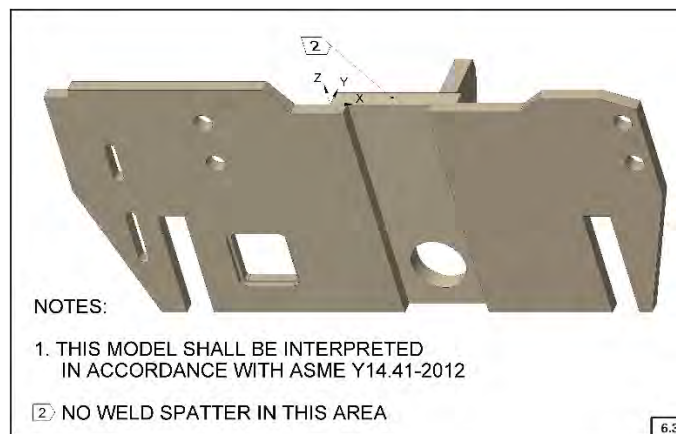

Y14.47 DRAFT 03 MAY 2018

Figure 6-X Site Map Example

CONFIDENTIAL AND PROPRIETARY TO ASME COMPANY.  
UNAUTHORIZED USE, DISCLOSURE, OR REPRODUCTION PROHIBITED.

COPYRIGHT © ASME COMPANY. ALL RIGHTS RESERVED.

EXPORT CONTROL CLASSIFICATION NUMBER: EAR 99.

THIS PART IS NOT ITAR RESTRICTED.

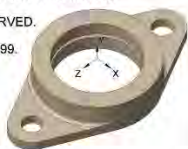

DAI: ASME COMPANY  
PART NUMBER: XYZ54236  
PART NAME: SUPPORT  
ORIGINATOR: JOHN DOE  
CAGE CODE: 60012  
MODEL UNITS: METRIC  
MODEL SCALE: 1:1  
CURRENT REVISION: A  
REVISION HISTORY: INITIAL RELEASE  
RELEASE STATE: COMPLETE  
MODEL CHECKED STATUS: COMPLETE  
DATA REVIEW STATUS: COMPLETE  
THIS MODEL CONFORMS TO ASME Y14.41-2012  
ADDITIONAL INFORMATION IN DATA SET: YES

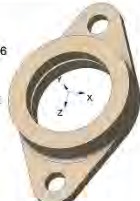

VIEW NAME	DESCRIPTION OF VIEW
MBD1_DEFAULT_NOTICES	DEFAULT VIEW, LEGAL NOTICE
MBD2_MANAGEMENT_DATA	DISPLAY OF MANAGEMENT DATA
MBD3_TITLES	TITLE BLOCK INFORMATION
MBD4_PROPERTIES	PROPERTIES OF THE PART
MBD5_GENERAL_NOTES	GENERAL NOTE INFORMATION
MBD6_SITE_MAP	VIEW FOR NAVIGATION BETWEEN PRESENTATION STATES
MBD7_MODEL_ONLY	AXONOMETRIC VIEW OF MODEL WITH NO ANNOTATIONS DISPLAYED
MBD8_DATUMS	VIEW TO DISPLAY THE DEFINITION OF DATUMS A, B AND C
MBD9_KEY_CHARACTERISTICS	KEY CHARACTERISTICS FOR THE MODEL BASED DEFINITION
MBD10_ALL_PMI	VIEW TO DISPLAY ALL MODEL 3D ANNOTATION
MBD11_FRONT_VIEW	VIEW TO DISPLAY DEFINITION FROM THE FRONT SIDE OF THE PART
MBD12_TOP_VIEW	VIEW TO DISPLAY DEFINITION FROM THE TOP SIDE OF THE PART
MBD13_RH_SIDE_VIEW	VIEW TO DISPLAY DEFINITION FROM THE RIGHT SIDE OF THE PART
MBD14_MACHINING	VIEW TO DISPLAY MACHINING OF PART
MBD15_SECTION_A-A	VIEW TO SHOW SECTION A-A INFORMATION
MBD16_DETAIL_B	ENLARGED VIEW TO SHOW DETAIL OF LOCATION





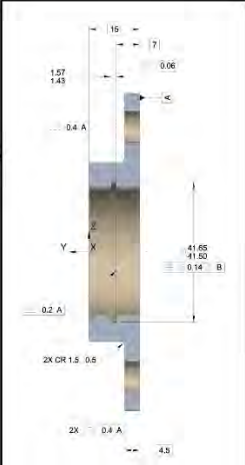

Clicking the view name results in activating the presentation state

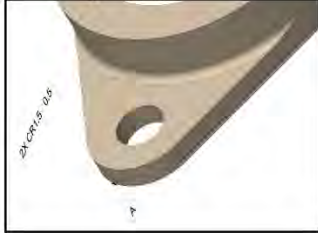
6.3

Y14.47 DRAFT 03 MAY 2018

Table 6-3 Metadata Elements

ALT_PART_NUMBER_*	Optional	String	<del>Part number</del> -PIN of an equal part for the product defined in the data set. When more than one alternate <del>part number</del> -PIN is supplied, append “_*” to the attribute name where a number(s) or letter(s) code is substituted for the “*”.	Category 2
CODE_EXPORT	Optional	String	Code for EAR Regulations from U.S. Dept. of Commerce, <del>or</del> ITAR Regulations from U.S. Dept. of State, <u>or AEA Regulations from U.S. Dept. of Energy.</u>	Category 1
GEOMETRIC_SCALE	Required	String	Scale of the model (e.g., <u>1:1</u> , 1:2).	Category 2
NEXT_ASSY	Optional	String	<del>Part number</del> -PIN of the next higher assembly using this product.	Category 2
PART_NUMBER	Required	String	<del>Number</del> -PIN for product defined in the data set. Required per ASME Y14.100.	Category 2
REV_DATE	Optional	ISO 8601 extended form date/time	Date of release for the current revision of the data set. <del>Include when the technical data package (TDP) is for released data.</del>	Category 2

# BSR/IIAR 7-201X

## Developing Operating Procedures for Closed-Circuit Ammonia Refrigeration Systems

### Public Review #4 Draft

This draft only shows one substantive change resulting from IIAR 7 Public Review #3 comments and enough additional language for understanding. If you have any questions, contact the IIAR Office at 1-703-312-4200.

#### Chapter 14. Tasks

**14.3 Equipment and Piping Opening Procedures.** The following items shall be considered when documenting equipment and piping opening procedures:

3. Equipment and/or piping that will be pumped out and/or opened to atmosphere shall be physically inspected prior to commencing work, ~~and the inspected equipment and piping compared against information provided on the refrigeration system diagrams, P&IDs, and/or photographs to confirm the location of the work.~~ and the location of the work confirmed and communicated to those performing the work.

## ANSI/IIAR 2-2014

## Addendum A

Standard for Safe Design of Closed-Circuit  
Ammonia Refrigeration Systems

## Public Review Draft #3

Reviewers of Addendum A are welcome to comment on the *changes* in the standard, indicated by underline and strikethrough text. Original parts of the standard are provided for context only.

Please refrain from commenting on layout, formatting and punctuation issues.

Comments on informative appendices are welcome but might not be formally addressed.

**Flammable Liquid:** A liquid whose flashpoint is ~~greater~~less than 100°F when tested by closed-cup test methods.

**4.2.4 \*Public Assembly, Commercial, Residential, and Large Mercantile Occupancies.** Where approved, ammonia refrigeration machinery shall be permitted outside of a machinery room for applications in a public assembly occupancy, commercial occupancy, or large mercantile occupancy. The quantity of ammonia shall be limited such that a complete discharge from any independent refrigerant circuit will not result in an ammonia concentration exceeding 300 ppm in any room or area where equipment containing ammonia is located. The calculation procedure for determining the concentration level shall comply with Chapter 5, Section 5.3.

## EXCEPTIONS:

1. ~~Listed P~~packaged vapor compression ~~or~~ absorption systems, with no refrigerant containing parts that are joined in the field by other than mating valves that permit sections of the system to be joined before opening the valves, installed in areas or rooms that are not public hallways or lobbies and with refrigerant quantities equal to or less than 6.6 lbs. (3 kg) are permitted for residential occupancies.
2. ~~Listed P~~packaged vapor compression or ~~or~~ absorption systems, with no refrigerant containing parts that are joined in the field by other than mating valves that permit sections of the system to be joined before opening the valves, installed in areas or rooms that are not public hallways or lobbies and with refrigerant quantities equal to or less than 22 lbs. (10 kg) are permitted for commercial occupancies.
3. ~~Listed, sealed P~~packaged vapor compression or absorption systems with no refrigerant containing parts that are joined in the field by other than mating valves that permit sections of the system to be joined before opening the valves, installed in public hallways or lobbies and with refrigerant quantities equal to or less than 3.3 lbs. (1.5 kg) are permitted for residential and commercial occupancies.

5.13.2.3 Equipment and piping designs based on the exception to Section 5.13.2 shall be required to comply with additional requirements in ASME B31.5 as applicable.

**6.7.2 Path of Travel.** The path of travel within the machinery room to at least one eyewash/safety shower unit shall be unobstructed and shall not include intervening doors. Additional eyewash/safety shower units shall be installed such that the path of travel in the machinery room is no more than 55 ft to an eyewash/safety shower unit. The path of travel to at least one eyewash/safety shower unit located outside of the machinery room shall be within 55 ft. of the principle machinery room door. The path of travel shall be unobstructed and shall not include intervening doors.

**6.15.1 NFPA 704 Placards.** A NFPA 704 placard shall be provided in accordance with Section 5.14.2 on or next to all doors through which a person can enter the machinery room.~~the principle machinery room door in accordance with Section 5.14.2.~~

**12.2.6\*** In applications where vessels are subject to external corrosion as determined by the owner or owner's designated agent, suitable means shall be used to address vessel protection. Carbon steel pressure vessels shall be designed and specified with a minimum of 1/16 in. (0.16 cm) external corrosion allowance. The external corrosion allowance is in addition to the minimum vessel thickness as required by ASME B&PVC, Section VIII, Division 1.

**EXCEPTIONS:**

1. ~~ASME stamped high side vessels, compressor oil separators and accompanying oil filters and oil coolers that are located indoors.~~
2. ~~The owner or the owner's designated agent specifies a different corrosion allowance.~~

15.2.3 Pressure relief devices shall not use cast iron seats or discs. ~~The design specifications of pressure relief devices shall limit the distortion of seats and discs such that distortion shall not cause a deviation greater than 5% of the set pressure within a span of 5 years.~~

**15.3.1 ASME Pressure vessels and ~~other types of Non-ASME E~~equipment**

**15.3.1.1** Pressure vessels and equipment built and stamped in accordance with ASME B&PVC, Section VIII, Division 1 shall be provided with pressure relief protection in accordance with the ASME B&PVC, Section VIII, Division 1.

**15.3.1.2** \*Equipment with an internal volume greater than 0.5 cubic feet that is not built in accordance ASME BPVC, Section VIII, Division 1 shall be provided with pressure relief protection that is in accordance with the ASME B&PVC Section VIII, Division 1.

EXCEPTION: This does not include compressors, pumps, controls, headers, piping, evaporators, condensers, and other types of equipment built in accordance with ASME B31.5.

**17.7 \*Detection and Alarm Levels.** Where this standard specifies an ammonia detection and alarm concentration, the operational criteria shall be as specified in this section.

**EXCEPTION:** Where approved, alternatives to fixed ammonia leak detectors shall be permitted for areas with high humidity or other harsh environmental conditions that are incompatible with detection devices.

**17.7.1 Level 1 Ammonia Detection and Alarm.** Level 1 ammonia detection and alarm shall have the following features:

1. At least one ammonia detector shall be provided in the room or area.

2. The detector shall activate an alarm that reports to a monitored location so that corrective action can be taken at an indicated concentration of 25 ppm or higher.

~~**17.7.2 Level 2 Ammonia Detection and Alarm.** Level 2 ammonia detection and alarm shall have the following features:~~

- ~~1. At least one ammonia detector shall be provided in the room or area.~~
- ~~1. The detector shall activate an alarm that reports to a monitored location so that corrective action can be taken at an indicated concentration of 25 ppm or higher.~~
- ~~2. Audible and visual alarms shall be provided inside the room to warn that, when the alarm has activated, access to the room is restricted to authorized personnel and emergency responders.~~

~~**17.7.3 Level 3 Ammonia Detection and Alarm.** Level 3 ammonia detection and alarm shall have the following features:~~

- ~~1. At least one ammonia detector shall be provided in the room or area.~~
- ~~1. The detector shall activate an alarm that reports to a monitored location so that corrective action can be taken at an indicated concentration of 25 ppm or higher.~~
- ~~2. Audible and visual alarms shall be provided inside the room to warn that, when the alarm has activated, access to the room is restricted to authorized personnel and emergency responders.~~
- ~~3. Upon activation of the alarm, control valves feeding liquid and hot gas to equipment in the affected area shall be closed. Refrigerant pumps, nonemergency fans, or other motors that are part of the ammonia refrigeration equipment in the room shall be de-energized.~~
- ~~4. Upon activation of the alarm, emergency exhaust systems, where required, shall be activated.~~

#### **(Informative) Explanatory Material.**

- A.5.17.4** The maximum volume of liquid in vessels has traditionally been considered 90% at a temperature of 90°F. Calculations can be done to determine other levels and worse case temperatures.

If hydrostatic relief is used to protect against overpressure due to hydraulic expansion, this does not eliminate the requirement for atmospheric relief if it is required elsewhere in this standard.

- A6.7.1** Eyewash/safety shower units should be located as closely as possible to the machinery room. The location and number of eyewash/safety showers should also be considered in a process hazard analyses.

- A12.2.6** ~~Pressure vessels used in ammonia refrigeration service are not generally subject to internal corrosion. There are however many of the low side vessels that have the potential to condense water on the outside of the vessel wherever the vessel temperature is consistently or intermittently below the dew point temperature of the surrounding air. For this reason 12.2.6 requires the addition of a 1/16 inch external corrosion allowance to all pressure vessels used in ammonia refrigeration systems that do not meet the requirements for the exceptions given. The exceptions cover vessels that are unlikely to corrode to any measurable extent, essentially warm painted vessels in machinery rooms. The second exception is to allow an owner's designated agent to specify a different, (either higher or lower) corrosion allowance if the owner chooses other methods to prevent corrosion; like painting, cathodic protection, corrosion control gel, or similar products, or determines that a greater corrosion allowance is required to meet the life expectation of a particular pressure vessel installation. In any location the requirements of the B&PV code Section VIII Division I specifies the minimum design thickness for vessels. For vessels specified without corrosion allowance, vessel fabricators, when requested, should provide buyers or their designated agents the ASME BPVC VIII-1 minimum thickness values (Tmin), for shell and heads. The Tmin values may exclude nozzle reinforcement locations but should account for~~



~~excess material used to satisfy impact test exemptions and other loadings including those listed in ASME BPVC VIII-1 paragraph UG-22. Unless provided by the manufacturer,  $T_{min}$  values within two diameters of an opening should be considered equal to the Manufacturer's Data Report U-1 or U-1A nominal material thickness value minus any ASME BPVC VIII-1 material tolerance. Plate ordered to a nominal value has a material under tolerance of the smaller of .01 inch (0.3 mm) or 6% of the nominal thickness<sup>1</sup>. Carbon and alloy steel welded and seamless pipe has a material under tolerance of 12.5% of nominal thickness.<sup>2</sup> ASME BPVC VIII-1 Paragraph UG-16(e) (2).~~

~~1. ASME BPVC II-A SA-530 Table 1.~~

~~Metal thickness less than new construction limits should be reviewed based on local jurisdictional guidelines and procedures. These may include aspects of the National Board Inspection Code (NBIC) NB-23 or API RP 579-1 / ASME FFS-1 Fitness for Service.~~

Carbon steel pressure vessels used in closed-circuit ammonia refrigeration systems may be subject to external corrosion. Corrosion is more likely in applications where the surface temperature of an uninsulated vessel periodically cycles or operates continuously below the dew point temperature in the area where it is installed, when the vessel is inadequately insulated, or when installed outdoors and unprotected from the weather (e.g. Receivers, Accumulators, Recirculators, Oil Pots, Transfer Vessels).

Accordingly, the user or his designated agent who knows how the vessel will be applied, should consider corrosion preventive measures where necessary when specifying new vessels. Preventive measures include painting, insulation, cathodic protection, corrosion control gel, or similar products. The addition of a corrosion allowance may be required to meet the life expectancy of a particular pressure vessel installation.

ASME Section VIII Div. 1 permits the use of plate material with under-tolerance that is the smaller of 0.01 in. (0.3mm) or 6% of the nominal material thickness. Vessels constructed in accordance with the rules of ASME section VIII Div. 1 using plate materials that have under-tolerance within the allowed ranges are compliant even though the plate material thickness could be less than the nominal wall thickness or the calculated minimum wall thickness and may be used at full design pressure. In these cases, pitting or surface corrosion can reduce life expectancy. Determination of suitability for continued service should be based on vessel inspection guidelines in section 10.1 of IIAR6. When pitting or surface damage exceeds these guidelines, vessel derating, wall repair by an ASME R stamp holder, or vessel replacement is required.

#### A.15.3.1.2

Plate type heat exchangers, plate freezers or any assemblies, subassemblies, accessories, or components of a refrigeration system, with internal volumes greater than or equal to 0.5 cubic feet, that are not specifically designed to comply to ASME B31.5 should be provided with pressure relief protection per section 15.3.

#### A.16.1.2

For refrigeration systems with automatic monitoring, the monitoring system should report alarms to a monitored location. Automatic monitoring systems for critical operating parameters should acquire and store data in a manner and for a time period that is compatible with the owner's intended inspection methods. For refrigeration systems with automatic monitoring, the monitoring system should automatically report critical alarms to a monitored location. Examples of critical alarms may include discharge pressure greater than the compressor high pressure cut out setting; ammonia concentration greater than 300ppm within an enclosed area; or other criteria that indicates a refrigerant release has occurred. Automatic monitoring systems for critical

operating parameters should acquire and store data in a manner and for a time period that is compatible with the owner's intended inspection methods.

#### **A.17.7**

The normative parts of this standard do not require ammonia detection and alarm levels other than level 1. Some end-users may prefer to use a more stringent level of detection and response. The following detection and alarm levels are possible alternatives:

**Level 2 Ammonia Detection and Alarm.** Level 2 ammonia detection and alarm shall have the following features:

1. At least one ammonia detector shall be provided in the room or area.
2. The detector shall activate an alarm that reports to a monitored location so that corrective action can be taken at an indicated concentration of 25 ppm or higher.
3. Audible and visual alarms shall be provided inside the room to warn that, when the alarm has activated, access to the room is restricted to authorized personnel and emergency responders.

**Level 3 Ammonia Detection and Alarm.** Level 3 ammonia detection and alarm shall have the following features:

1. At least one ammonia detector shall be provided in the room or area.
2. The detector shall activate an alarm that reports to a monitored location so that corrective action can be taken at an indicated concentration of 25 ppm or higher.
3. Audible and visual alarms shall be provided inside the room to warn that, when the alarm has activated, access to the room is restricted to authorized personnel and emergency responders.
4. Upon activation of the alarm, control valves feeding liquid and hot gas to equipment in the affected area shall be closed. Refrigerant pumps, nonemergency fans, or other motors that are part of the ammonia refrigeration equipment in the room shall be de-energized.
5. Upon activation of the alarm, emergency exhaust systems, where required, shall be activated.

Tracking number 455-2i1r3  
© 2018 NSF International

New Standard NSF/ANSI 455-2 – 201X  
Issue 1, Revision 3 (September 2018)

Not for publication. This document is part of the NSF International standard development process. This draft text is for circulation for review and/or approval by a NSF Standards Committee and has not been published or otherwise officially adopted. All rights reserved. This document may be reproduced for informational purposes only.

[Note – the recommended changes to the standard which include the current text of the relevant section(s) indicate deletions by use of ~~strikeout~~ and additions by **gray highlighting**. Rationale statements are in *italics* and only used to add clarity; these statements will NOT be in the finished publication.]

NSF/ANSI Standard  
for Good Manufacturing Practices –

## Good manufacturing practices for dietary supplements

- 
- 
- 

### 4 Audit requirements

- 
- 
- 

#### 4.6 Performance evaluation

- 
- 
- 

**4.6.9** Other raw materials or components (i.e., those that are not dietary ingredients) shall be sampled, tested (or confirmed), and released prior to use in production. Conduct appropriate tests or examinations (or rely on Certificate of Authenticity Analysis (COA) from the qualified supplier). [21CFR111.75(a2i)]

- 
- 
- 

**4.6.24** Records for each product complaint and investigation shall be maintained. Records shall be maintained for at least one year after the shelf life date, if shelf life dating is being used, or at least two years beyond the date of distribution of the last batch associated with those records. [21CFR111.570(a) & 21CFR117.139]

**4.6.25** Procedures shall be established to define the recall of a product. The written recall plan shall include procedures that describe the steps to be taken, and assign responsibility for taking those steps as appropriate to the facility. [21CFR117.139]

- 
- 
- 

### 5 Audit process

- 
- 
- 

#### 5.2 Audit and certification process outline

a) Educate / inform

- audit preparation;
- review and understand 21CFR111 and 21CFR117:

Tracking number 455-2i1r3  
 © 2018 NSF International

New Standard NSF/ANSI 455-2 – 201X  
 Issue 1, Revision 3 (September 2018)

Not for publication. This document is part of the NSF International standard development process. This draft text is for circulation for review and/or approval by a NSF Standards Committee and has not been published or otherwise officially adopted. All rights reserved. This document may be reproduced for informational purposes only.

- visit [Electronic Code of Federal Regulations for 21CFR111](http://www.ecfr.gov/cgi-bin/text-idx?SID=b4afc2a388d92aef79afbaf247790&mc=true&node=pt21.2.111&rgn=div5) <www.ecfr.gov/cgi-bin/text-idx?SID=b4afc2a388d92aef79afbaf247790&mc=true&node=pt21.2.111&rgn=div5>; and
- visit [Electronic Code of Federal Regulations for 21CFR117](http://www.ecfr.gov/cgi-bin/text-idx?SID=b4afc2a388d92aef79afbaf247790&mc=true&node=pt21.2.117&rgn=div5) <www.ecfr.gov/cgi-bin/text-idx?SID=b4afc2a388d92aef79afbaf247790&mc=true&node=pt21.2.117&rgn=div5>.

- 
- 
- 
- 
- 
- 

**5.4.3 Finalize the audit report and determine audit grade**

Table 5.2 below presents the grade to be awarded as a result of the audit nonconformances.

**Table 5.2 – Summary of grading model**

Grade	Critical	Major	Minor
A	0	0	≤ 7
B	0	1	≤ 7
B	0	0	8 to 15
C	0	1	≤ 15 8-15
C	0	0	16 to 22
D	≥ 1	—	—
D	0	≥ 2	—
D	0	1	≥ 16 16
D	0	0	≥ 23 23

**BSR/UL 489, Standard for Safety for Molded-Case Circuit Breakers, Molded-Case Switches and Circuit-Breaker Enclosures, UL 489**

7.1.9.1 A circuit breaker shall be capable of withstanding for 1 minute without breakdown the application of a 48 - 62 Hz essentially sinusoidal potential of 1000 V plus twice the voltage that is to be applied between the parts in question, when the breaker is connected in accordance with its maximum voltage rating:

- a) Between line and load terminals with the breaker open - with the breaker in the tripped and off positions. The test voltages shall be based on the voltage rating of the circuit breaker. The test voltage for a circuit breaker rated for a wye-connected system shall be based on the phase-to-phase voltage;
- b) Between terminals of opposite polarity with the breaker closed. The test voltages shall be based on the voltage rating of the circuit breaker. The test voltage for a circuit breaker rated for a wye-connected system shall be based on the phase-to-phase ~~phase-to-neutral~~ voltage; and
- c) Between live parts and the overall enclosure, as described in 7.1.1.25, with the breaker both open and closed. The test voltage for a circuit breaker rated for a wye connected system shall be based on the phase-to-neutral voltage.

**Table 7.1.7.1**

**Interrupting test operations<sup>a</sup>**

Poles	Frame rating	Circuit breaker AC voltage rating	Letters indicate diagram in Figure 7.1.7.1						Total number of operations
			Operations on each pole			Common operations			
			O	CO	O	O	CO	O	
1	All	120, 127, 208, 240, 277, 347, 480, 600, <u>650</u> , <u>690</u> , <u>700</u> or 1000	A	A	A	-	-	-	3
1	All	120/240 (tested in pairs)	-	-	-	B	B	B	3
2	All	240, 480, 600, or 1000 or any wye connected system ratings or any <u>delta connected</u> (wye connected)	E	E	-	D	-	-	5

UL copyrighted material. Not authorized for further reproduction without permission from UL.

		<u>system rating between 600V and 1000V.</u>							
2	All	120/240	-	-	-	C	C	C	3
2	0 - 1200 A	208Y/120, 480Y/277, or 600Y/347 or any wye connected system ratings or any delta connected (wye connected) <u>system rating between 600V and 1000V.</u>	L	L	-	C		-	5
2	All	1 $\phi$ - 3 $\phi$	E	E		H	-	-	5
3	0 - 1200 A	240, 480, 600, or 1000 or any wye connected system ratings or any delta connected (wye connected) <u>system rating between 600V and 1000V.</u>	G	G	-	F	-	-	7
3	1200 - Up	240, 480, 600, or 1000 or any wye connected system ratings or any delta connected (wye connected) <u>system rating between 600V and 1000V.</u>	G	G	-	F	-	-	7
3	All	120/240	-	-	-	J	J	J	3
3	All	208Y/120, 480Y/277,	K	K	-	I	-	-	7

UL copyrighted material. Not to be reproduced without prior permission from UL.

		<u>600Y/347 or any wye connected system ratings or any delta connected (wye connected) system rating between 600V and 1000V.</u>							
4	All	<u>208Y/120, 480Y/277, 600Y/347, or any wye connected system ratings or any delta connected (wye connected) system rating between 600V and 1000V.</u>	K	K	M	-	-		7

<sup>a</sup> For the 125/250 V dc rating, the number of operations is the same as for the 120/240 V ac rating. For the 250 V dc rating, the number of operations is the same as for the 240 V ac rating.

**UL copyrighted material. Not authorized for further reproduction without prior permission from UL.**